

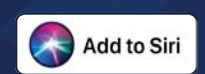

PRODUCT SHEET COLLECTION

GUIDING INNOVATION, ONE PRODUCT AT A TIME.

SEE THE LATEST INSIDE!



LED SMART SLIMFIT DOWNLIGHTS

FLAT LENS | REMOTE DRIVER



STARFISH™
Controlled with App



Millions of Colors

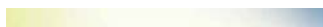

Warm to Cool Tunable White

4" AND 6" MODELS IN ROUND AND SQUARE

STARFISH™ SMART ENABLED PRODUCT

RGB, COLOR-CHANGING & TUNABLE WHITE

PRE-SET AND CUSTOM EFFECTS

SUGGESTED APPLICATIONS:

Residential, Multifamily, Commercial, Hospitality, Offices

SATCO|NUVO's LED Slimfit Downlights with STARFISH™ technology are the ultimate choice for smart lighting and ambiance control. Download the STARFISH™ app to customize any tunable white color temperatures from 2000K warm white light to 5000K natural light, or choose from millions of colors on the RGB spectrum, all from your mobile device. Offered in round and square, with flat lens, these slimfit downlights are ideal for transforming residential and multifamily environments.

These downlights are also compatible with Siri, Alexa, Google Home, and SmartThings so they can be easily incorporated into your smart home.

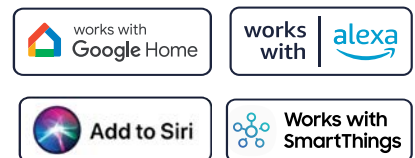

GENERAL SPECIFICATIONS

Input Voltage, Frequency: 120V, 60Hz
Power Factor, THD%: >0.9, <30%
Tunable White CCT: 2000K-5000K
RGB: Millions of colors
Functional Life: 50,000 Hours
Dimmable: Only with STARFISH™ app
CRI: 90
Efficacy: up to 62 LPW
Beam Angle: 110°

Construction: Aluminum
Finish: White
Lens: Polycarbonate
Ambient Operating Temperature:
 -20°C (-4°F) to +40°C (+104°F)
Location Rating: Wet
IC Rating: Yes



ITEM SPECIFICATIONS / ORDER INFO

Item	Size	Shape	Lumens	Wattage	Incandescent Replacement Wattage	Input Current	Master Carton
S11560	4"	Round	540	9W	45W	0.08A	20
S11561	4"	Square	540	9W	45W	0.08A	20
S11562	6"	Round	750	12W	60W	0.10A	20
S11563	6"	Square	750	12W	60W	0.10A	20

DIMENSIONS/WEIGHTS

Item	Diameter/Width (A)	Length (B)	Height (C)	Weight
S11560	5.00"	•	1.00"	0.88 Lbs.
S11561	5.04"	5.04"	1.00"	0.99 Lbs.
S11562	7.17"	•	1.00"	1.15 Lbs.
S11563	7.13"	7.13"	1.00"	1.28 Lbs.

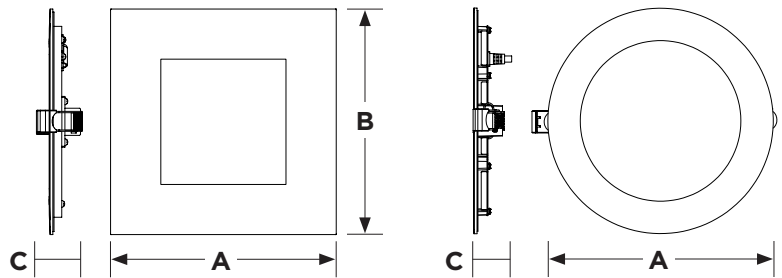

OPTIONAL ACCESSORIES

Item	Description
80-943	4" Adjustable Rough-In Mounting Plate
80-944	6" Adjustable Rough-In Mounting Plate
80-950	4" Rough-In Mounting Plate
80-952	6" Mounting Plate for New Construction
80-946	4" Round Goof Ring
80-947	6" Round Goof Ring
80-986	6' Remote Driver Extension Cable

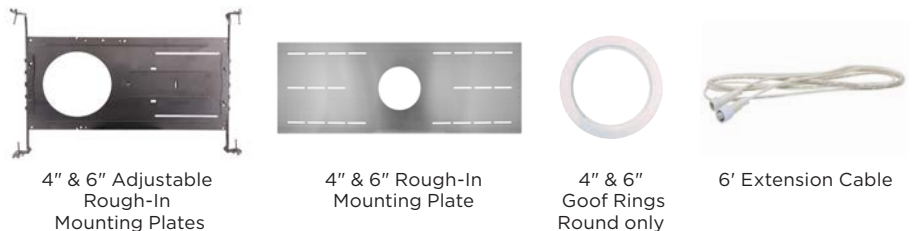

DOWNLOAD THE STARFISH APP



CONNECT
Download the STARFISH™ app

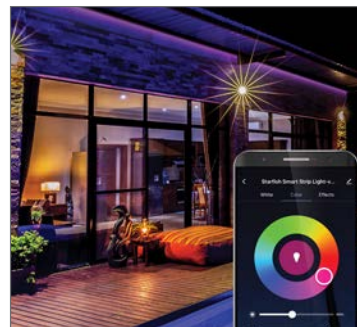

INSTALL
Pair the smart downlights and configure your settings



ENJOY
The convenience and customization of smart lighting

This device complies with Part 15 of the FCC Rules. Operation is subject to the following two conditions: (1) this device may not cause harmful interference, and (2) this device must accept any interference received, including interference that may cause undesired operation.

WARNING: Some products included in this specification sheet may be subject to the warning requirements of California's Proposition 65. Please refer to your product packaging for more information.

Replacement wattage shown depends on application and fixture. Specifications are subject to change without prior notice.

Amazon, Alexa and all related logos are trademarks of Amazon.com, Inc. and its affiliates. Siri is a registered trademark of Apple Inc. Google, Google Play and Google Home are trademarks of Google LLC.

LED SMART SLIMFIT DOWNLIGHTS

SMOOTH BAFFLE | REMOTE DRIVER



STARFISH™
Controlled with App

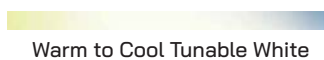

SATCO|NUVO's LED Slimfit Downlights with STARFISH™ technology are the ultimate choice for smart lighting and ambiance control. Download the STARFISH™ app to customize any tunable white color temperatures from 2000K warm white light to 5000K natural light, or choose from millions of colors on the RGB spectrum, all from your mobile device. Offered in round and square with a smooth baffle to reduce glare, these slimfit downlights are ideal for transforming residential and multifamily environments.

These downlights are also compatible with Siri, Alexa, Google Home, and SmartThings so they can be easily incorporated into your smart home.



**4" & 6" MODELS IN
ROUND & SQUARE**

**STARFISH™ SMART ENABLED
PRODUCT**

**SMOOTH BAFFLE
REDUCES GLARE**

**RGB, COLOR-CHANGING &
TUNABLE WHITE**

**PRE-SET AND CUSTOM
EFFECTS**

SUGGESTED APPLICATIONS:
Residential, Multifamily,
Commercial, Hospitality,
Offices

GENERAL SPECIFICATIONS

Input Voltage, Frequency: 120V, 60Hz
Power Factor, THD%: >0.9, <30%
Tunable White: 2000K-5000K CCT
RGB: Millions of Colors
Dimmable: Only with STARFISH™ App
CRI: 90
Efficacy: up to 62 LPW
Beam Angle: 110°

Construction: Aluminum
Finish: White
Lens: Polycarbonate
Ambient Operating Temperature: -20°C (-4°F) to +40°C (+104°F)
Location Rating: Wet
IC Rating: Yes



ITEM SPECIFICATIONS / ORDER INFO

Item	Size	Shape	Lumens	Wattage	Incandescent Replacement Wattage	Input Current	Master Carton
S11564	4"	Round	540	9W	45W	0.08A	20
S11565	4"	Square	540	9W	45W	0.08A	20
S11566	6"	Round	750	12W	60W	0.10A	20
S11567	6"	Square	750	12W	60W	0.10A	20

OPTIONAL ACCESSORIES

Item	Description
80-943	4" Adjustable Rough-In Mounting Plate
80-944	6" Adjustable Rough-In Mounting Plate
80-950	4" Rough-In Mounting Plate
80-952	6" Mounting Plate for New Construction
80-946	4" Goof Ring
80-947	6" Goof Ring
80-986	6' Remote Driver Extension Cable

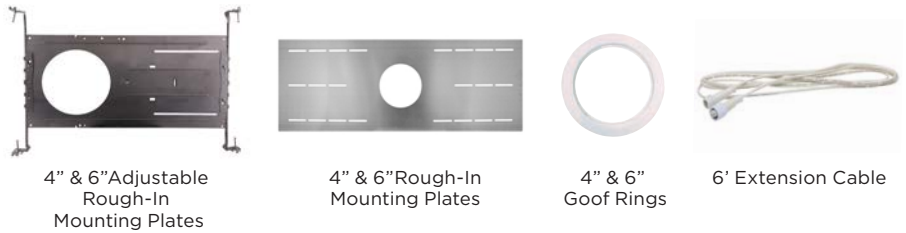

DIMENSIONS/WEIGHTS

Item	Diameter/Width (A)	Length (B)	Height (C)	Weight
S11564	5.00"	•	1.25"	0.93 Lbs.
S11565	5.00"	5.00"	1.25"	1.04 Lbs.
S11566	7.17"	•	1.25"	1.19 Lbs.
S11567	7.13"	7.13"	1.25"	1.32 Lbs.

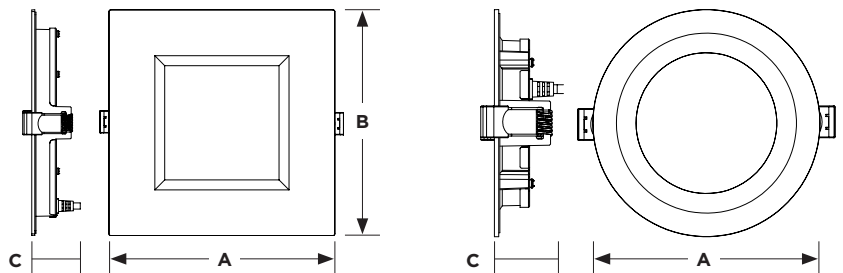

DOWNLOAD THE STARFISH APP



CONNECT
Download the STARFISH™ app

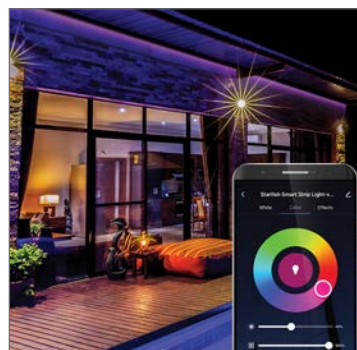

INSTALL
Pair the smart downlights and configure your settings



ENJOY
The convenience and customization of smart lighting

This device complies with Part 15 of the FCC Rules. Operation is subject to the following two conditions: (1) this device may not cause harmful interference, and (2) this device must accept any interference received, including interference that may cause undesired operation.

WARNING: Some products included in this specification sheet may be subject to the warning requirements of California's Proposition 65. Please refer to your product packaging for more information.

Replacement wattage shown depends on application and fixture. Specifications are subject to change without prior notice.

Amazon, Alexa and all related logos are trademarks of Amazon.com, Inc. and its affiliates. Siri is a registered trademark of Apple Inc. Google, Google Play and Google Home are trademarks of Google LLC.

LED SMART RETROFIT DOWNLIGHTS

STEPPED BAFFLE



STARFISH™
Controlled with App



E26 Adapter Included

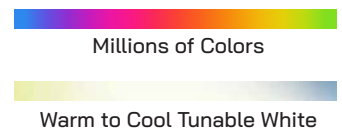

SATCO|NUVO's LED Retrofit Downlights with STARFISH™ technology are the ultimate choice for smart lighting and ambiance control. Download the STARFISH™ app to customize any tunable white color temperatures from 2000K warm white light to 5000K natural light, or choose from millions of colors on the RGB spectrum, all from your mobile device. Available in round and square with stepped baffle, these trims offer added dimension while reducing glare.

These downlights are also compatible with Siri, Alexa, Google Home, and SmartThings so they can be easily incorporated into your smart home.



4" & 6" MODELS IN ROUND & SQUARE

STEPPED BAFFLE REDUCES GLARE

STARFISH™ SMART ENABLED PRODUCT

RGB, COLOR-CHANGING & TUNABLE WHITE

PRE-SET & CUSTOM EFFECTS

SUGGESTED APPLICATIONS

Residential, Multifamily
Commercial, Hospitality,
Offices



WIFI
2.4GHz
No Hub Required



GENERAL SPECIFICATIONS

Input Voltage, Frequency: 120V, 60Hz
Power Factor, THD%: >0.9, <30%
Tunable White: 2000K-5000K CCT
RGB: Millions of Colors
Dimmable: Only with Starfish App
CRI: 90
Efficacy: up to 65 LPW
Beam Angle: 110°

Construction: Aluminum
Finish: White
Lens: Polycarbonate
Ambient Operating Temperature:
 -20°C (-4°F) to +40°C (+104°F)
Location Rating: Wet
IC Rating: Yes



ITEM SPECIFICATIONS / ORDER INFO

Item	Size	Shape	Lumens	Wattage	Incandescent Replacement Wattage	Input Current	Master Carton
S11568	4"	Round	650	10.5W	50W	0.09A	24
S11569	4"	Square	650	10.5W	50W	0.09A	24
S11570	6"	Round	850	13W	65W	0.11A	12
S11571	6"	Square	850	13W	65W	0.11A	12

DIMENSIONS/WEIGHTS

Item	Diameter/Width (A)	Length (B)	Height (C)	Weight
S11568	5.00"	•	2.71"	0.40 Lbs.
S11569	5.00"	5.00"	2.71"	0.57 Lbs.
S11570	7.32"	•	3.03"	0.57 Lbs.
S11571	6.77"	6.77"	3.38"	0.97 Lbs.

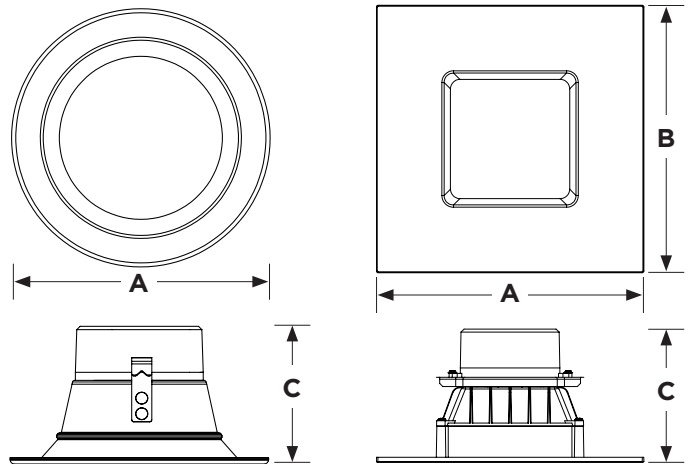

STARFISH™
 live life enlIghtened



DOWNLOAD THE STARFISH APP



CONNECT
 Download the STARFISH™ app

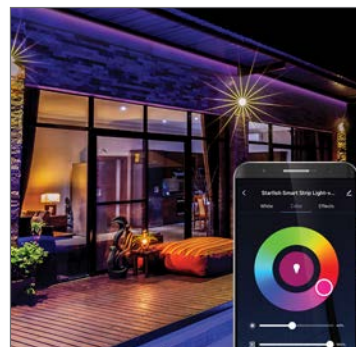

INSTALL
 Pair the smart downlights and configure your settings



ENJOY
 The convenience and customization of smart lighting

This device complies with Part 15 of the FCC Rules. Operation is subject to the following two conditions: (1) this device may not cause harmful interference, and (2) this device must accept any interference received, including interference that may cause undesired operation.

WARNING: Some products included in this specification sheet may be subject to the warning requirements of California's Proposition 65. Please refer to your product packaging for more information.

Replacement wattage shown depends on application and fixture. Specifications are subject to change without prior notice.

Amazon, Alexa and all related logos are trademarks of Amazon.com, Inc. and its affiliates. Siri is a registered trademark of Apple Inc. Google, Google Play and Google Home are trademarks of Google LLC.

LED SMART DIRECTIONAL LOW-PROFILE DOWNLIGHTS

REMOTE DRIVER

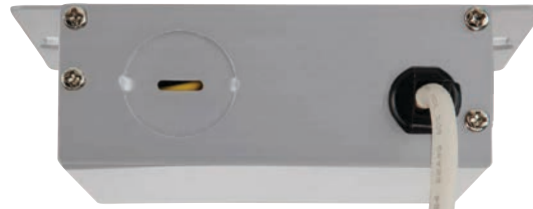

STARFISH™
Controlled with App

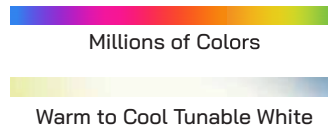

**4" & 6" ROUND MODELS
IN BLACK & WHITE**

**STARFISH™ SMART ENABLED
PRODUCT**

**RGB, COLOR-CHANGING &
TUNABLE WHITE**

PRE-SET & CUSTOM EFFECTS

SUGGESTED APPLICATIONS

Residential, Multi-family,
Commercial, Retail, Offices

SATCO|NUVO's LED Directional Low-Profile Downlights with STARFISH™ technology are the ultimate choice for smart lighting and ambiance control. Download the STARFISH™ app to customize any tunable white color temperatures from 2700K warm white light to 5000K natural light, or choose from millions of colors on the RGB spectrum, all from your mobile device. The 360° rotation and 0° to 80° tilt allow for the light to be positioned as needed, focusing light where it's needed most.

These downlights are also compatible with Siri, Alexa, Google Home, and SmartThings so they can be easily incorporated into an existing automated system.



WIFI
2.4GHz
No Hub Required



GENERAL SPECIFICATIONS

Range Voltage, Frequency: 120V-277V, 60Hz
Power Factor: >0.9
Tunable White CCT: 2700K-5000K
RGB: Millions of colors
Functional Life: 50,000 Hours
Dimmable: Only with STARFISH™ app
CRI: 90
Efficacy: up to 80 LPW
Beam Angle: 36°
Aiming Angle: 80°

Rotation: 360°
Construction: Aluminum
Shape: Round
Lens: Plastic
Ambient Operating Temperature:
 -20°C (-4°F) to +45°C (+113°F)
Location Rating: Damp
IC Rating: Yes



ITEM SPECIFICATIONS / ORDER INFO

Item	Size	Shape	Finish	Lumens	Wattage	Incandescent Replacement Wattage	Input Current	Master Carton
S11293	4"	Round	White	650	9W	50W	0.08 - 0.03A	12
S11294	4"	Round	Black	650	9W	50W	0.08 - 0.03A	12
S11295	6"	Round	White	1,200	15W	75W	0.13 - 0.05A	12
S11296	6"	Round	Black	1,200	15W	75W	0.13 - 0.05A	12

OPTIONAL ACCESSORIES

Item	Description
80-943	4" Adjustable Rough-In Mounting Plate
80-944	6" Adjustable Rough-In Mounting Plate
80-950	4" Rough-In Mounting Plate
80-951	6" Rough-In Mounting Plate
80-946	4" Round Goof Ring
80-947	6" Round Goof Ring
80-949	6' Remote Driver Extension Cable

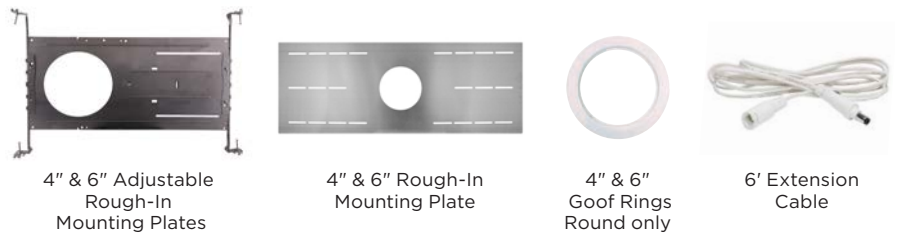

DIMENSIONS/WEIGHTS

Item	Diameter (A)	Height (B)	Weight
4"	4.92"	1.44"	0.99lbs
6"	7.48"	2.13"	1.22lbs

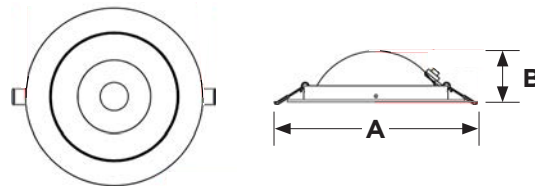

DOWNLOAD THE STARFISH APP



CONNECT
Download the STARFISH™ app

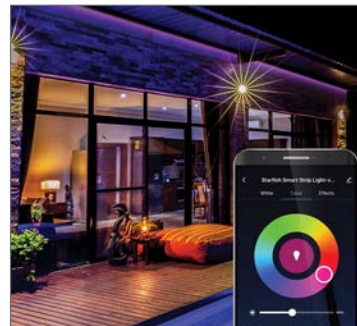

INSTALL
Pair the smart downlights and configure your settings



ENJOY
The convenience and customization of smart lighting

This device complies with Part 15 of the FCC Rules. Operation is subject to the following two conditions: (1) this device may not cause harmful interference, and (2) this device must accept any interference received, including interference that may cause undesired operation.

WARNING: Some products included in this specification sheet may be subject to the warning requirements of California's Proposition 65. Please refer to your product packaging for more information.

Replacement wattage shown depends on application and fixture. Specifications are subject to change without prior notice.

Amazon, Alexa and all related logos are trademarks of Amazon.com, Inc. and its affiliates. Siri is a registered trademark of Apple Inc. Google, Google Play and Google Home are trademarks of Google LLC.

LACEY COLLECTION

LED SMART COLOR CHANGING PENDANTS

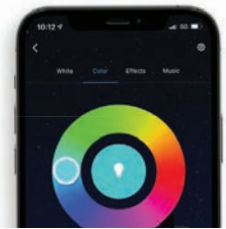

STARFISH®
Controlled with App

Millions of Colors

Warm to Cool Tunable White



STARFISH® SMART ENABLED PRODUCTS

THREE PENDANT STYLES AVAILABLE

ADVANCED PAIRING TECHNOLOGY

RGB, COLOR-CHANGING & TUNABLE WHITE

PRE-SET AND CUSTOM COLOR-CHANGING EFFECTS

SUGGESTED APPLICATIONS

Showrooms, Retail, Hospitality,
Commercial, Residential
Multi-Family

The Lacey LED pendant collection combines sophisticated design with the advanced functionality of STARFISH® Smart technology. Featuring beautiful lead free bubble crystal, these fixtures create a stunning interplay of light, texture, and color. Each bubble sparkles with vibrant hues, while traditional white tones, ranging from warm to natural light, offer a more classic lighting option. STARFISH® Smart technology makes adjusting these settings effortless through its intuitive app, letting you customize your space with ease. Matte black accents enhance the crystal's brilliance, elevating your home with an artistic touch that merges luxury and modern style.



STARFISH® ENABLED PRODUCT



GENERAL SPECIFICATIONS

Input Voltage: 120V
Frequency: 60Hz
Power Factor: >0.9
Efficacy: 95 LPW
CCT Tunable White: 2000K-5000K with STARFISH® App
RGB: Millions of Colors
CRI: 80+
Dimming: Dimmable Only with STARFISH® App

Location Rating: Damp
Ambient Operating Temperature: -20°C (-4°F) to 50°C (+122°F)
Finish: Matte Black
Pendant Construction Material: Steel
Glass Type: K9 Bubble Crystal
Functional Life: 35,000 Hours
Warranty: 3 Years



ITEM SPECIFICATIONS/ORDERING INFO

Item	Description	Wattage	Replacement Wattage	Lumens	Wire Length	Max Rod Length
62-6001	Pendant	11.5W	75W	1100	144"	--
62-6002	Pendant	11.5W	75W	1100	144"	--
62-6003	Island Pendant	11.5W	75W	1100	144"	36" (Comes with Four 6" Stems and Four 12" Stems)

DIMENSIONS / WEIGHTS

Item	Height (A)	Diameter (B)	Length (C)	Weight
62-6001	13.13"	2.25"	-	4.62 Lbs.
62-6002	10.25"	3.75"	-	6.16 Lbs.
62-6003	-	2.25"	22.75"	9.90 Lbs.

OPTIONAL PENDANT ACCESSORIES (SOLD SEPARATELY)

Item	Description
TP143	Monopoint Adapter; Black Finish
TP245	Stem Hung Pendant Track Adapter; Black Finish
TP247	Single Monopoint Adapter; Round; Black Finish
TP249	Triple Monopoint Adapter; Round; Black Finish
TP251	Double Monopoint Adapter; Rectangular; Black Finish
TP253	Triple Monopoint Adapter; Rectangular; Black Finish

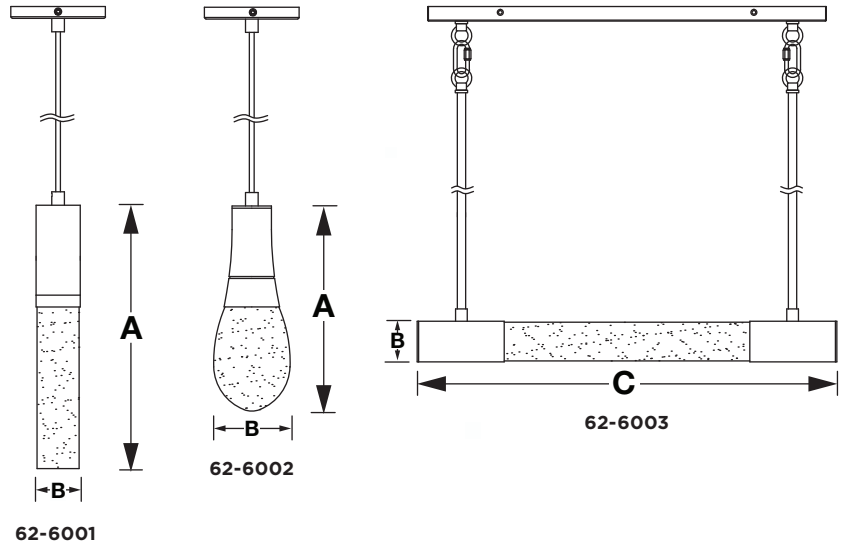

DOWNLOAD THE STARFISH® APP



CONNECT
Download the STARFISH® app



INSTALL
Pair and configure your settings

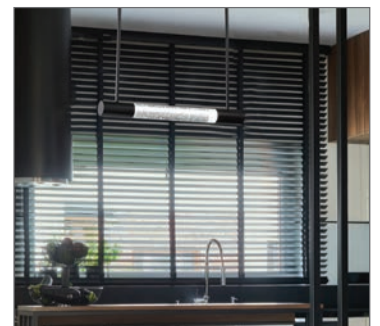

ENJOY
The convenience and customization of smart lighting

This device complies with Part 15 of the FCC Rules. Operation is subject to the following two conditions: (1) this device may not cause harmful interference, and (2) this device must accept any interference received, including interference that may cause undesired operation.

WARNING: Some products included in this specification sheet may be subject to the warning requirements of California's Proposition 65. Please refer to your product packaging for more information.

Amazon, Alexa and all related logos are trademarks of Amazon.com, Inc. and its affiliates. Siri is a registered trademark of Apple Inc. Google, Google Play and Google Home are trademarks of Google LLC.

Visit satco.com/service/warranty for complete warranty details.

SMART LED TRACK HEADS

ROUND AND PINCH BACK STYLES



STARFISH[®]
Controlled with App

Millions of Colors

Warm to Cool Tunable White

COMPATIBLE WITH SATCO SINGLE
CIRCUIT H-TRACK SYSTEMS

STARFISH[®] SMART ENABLED
PRODUCT

ADVANCED PAIRING
TECHNOLOGY

RGB COLOR-CHANGING &
TUNABLE WHITE

PRE-SET AND CUSTOM
COLOR-CHANGING EFFECTS

SUGGESTED APPLICATIONS:

Showrooms, Retail,
Hospitality, Commercial,
Residential, Multi-family

SATCO|NUVO's LED SMART Track Heads with STARFISH[®] technology present the timeless appeal of track lighting fused with the contemporary design and conveniences of intelligent lighting. Download the STARFISH app to customize any tunable white color temperatures from 2000K warm white light to 5000K natural light or choose from millions of colors on the RGB spectrum, all from your mobile device. Available in round or pinch-back shapes, and offered in sleek black or white finishes, these track heads boast adjustability, enabling you to pivot per your lighting requirements. Experience vibrant hues, seamless control, and enchanting lighting effects tailored to your unique style and preferences with these SMART track fixtures.



STARFISH[®] ENABLED PRODUCT



GENERAL SPECIFICATIONS

Input Voltage, Frequency: 120V, 50/60Hz

Power Factor, THD%: 0.94, 30%

Wattage: 12W

Incandescent Replacement Wattage: 60W

Input Current: 0.10A

Efficacy: 91 LPW

CCT Tunable: 2000K-5000K with STARFISH® App

RGB: Millions of colors

CRI: 80

Dimmable: Yes-only with STARFISH® App*

Lumens: 1100

Beam Angle: 36°

Functional Life: 50,000 Hours

Location Rating: Dry

Ambient Operating Temperature:-15°C (+5°F) to +50°C (+122°F)

Track Type: SATCO H-Track Compatible

Construction: Die-Cast Aluminum

Lens Material: Poly Methyl Methacrylate (PMMA)

Warranty: 3 Year





ITEM SPECIFICATIONS / ORDER INFO

Item	Finish	Shape
TH903	Matte White	Round
TH904	Matte Black	Round
TH913	Matte White	Pinch Back
TH914	Matte Black	Pinch Back

DIMENSIONS/WEIGHTS

Item	Width (A)	Length (B)	Extension (C)	Weight
TH903	5.38"	2.25"	6.38"	1.10 Lbs.
TH904	5.38"	2.25"	6.38"	1.10 Lbs.
TH913	5.91"	2.83"	5.63"	1.30 Lbs.
TH914	5.91"	2.83"	5.63"	1.30 Lbs.

OPTIONAL ACCESSORIES (SOLD SEPARATELY)

Item	Description
TP176	Offset Monopoint: Square; White Finish 
TP177	Offset Monopoint: Square; Black Finish 

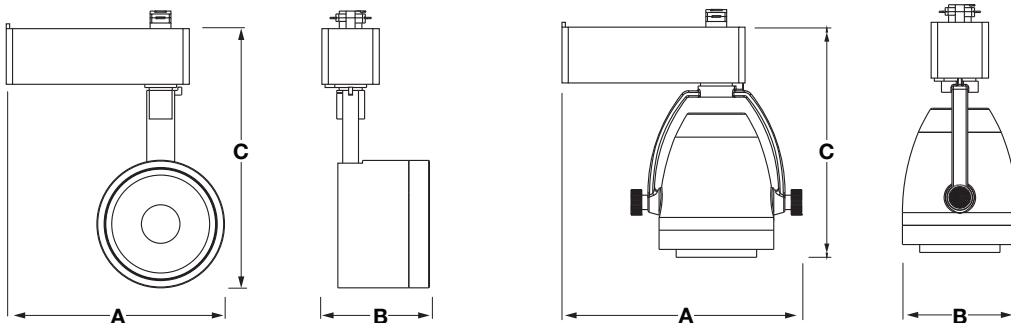

DOWNLOAD THE STARFISH APP



CONNECT
Download the STARFISH® app



INSTALL
Pair the smart downlights and configure your settings



ENJOY
The convenience and customization of smart lighting

This device complies with Part 15 of the FCC Rules. Operation is subject to the following two conditions: (1) this device may not cause harmful interference, and (2) this device must accept any interference received, including interference that may cause undesired operation.

WARNING: Some products included in this specification sheet may be subject to the warning requirements of California's Proposition 65. Please refer to your product packaging for more information. Replacement wattage shown depends on application and fixture. Specifications are subject to change without prior notice.

* Not for use with in-wall dimmer switches.

Amazon, Alexa and all related logos are trademarks of Amazon.com, Inc. and its affiliates. Siri is a registered trademark of Apple Inc. Google, Google Play and Google Home are trademarks of Google LLC.



DECORATIVE RIBBON FILAMENT

**THREE DIFFERENT
BULB SHAPES**

**STARFISH® SMART
ENABLED PRODUCT**

**ADVANCED PAIRING
TECHNOLOGY**

**RGB COLOR-CHANGING &
TUNABLE WHITE**

PRE-SET AND CUSTOM EFFECTS

SUGGESTED APPLICATIONS

Showrooms, Residential,
Multi-Family, Hospitality,
Retail, Commercial

SMART COLOR CHANGING BULBS

MEDIUM BASE | CANDELABRA BASE



STARFISH®
Controlled with App

Millions of Colors

Warm to Cool Tunable White

SATCO|NUVO's STARFISH® SMART technology color changing light bulbs feature an eye-catching RGBTW decorative ribbon filament that is beautifully showcased through the clear glass bulb. Available in A19, ST19, and B11 bulb types with both medium E26 and a candelabra E12 base, these bulbs offer flexibility for a range of fixtures. With tunable white options from a warm 2700K to a crisp 5000K and access to millions of vibrant RGB colors, they create the perfect ambiance for any space. Fully dimmable and controlled via the Starfish Smart app, users can easily customize lighting scenes and enjoy dynamic color effects. These bulbs seamlessly blend classic design with modern smart capabilities.

These elegant bulbs are also compatible with Siri, Alexa, Google Home, and SmartThings so they can be easily incorporated into your smart home.



GENERAL SPECIFICATIONS

Input Voltage: 120V
Frequency: 60Hz
Power Factor: 0.7
Efficacy: 75 LPW
CCT Tunable: 2700K-5000K with STARFISH® App
RGB: Millions of Colors
Dimmable: Yes, only with STARFISH® App
CRI: 90

Beam Angle: 320°
Location Rating: Damp
Ambient Operating Temperature: -20°C (-4°F) to +40°C (+104°F)
Rated for Enclosed Fixture: Yes
Material: Glass
Lens Finish: Clear
Functional Life: 15,000 Hours
Warranty: 3 Years



ITEM SPECIFICATIONS / ORDER INFO

Item	Lamp Shape	Lamp Base	Wattage	Replacment Wattage	Lumens	THD %
S11240	ST19	Medium	6W	40W	450	89.20%
S11241	A19	Medium	6W	40W	450	89.20%
S11242	B11	Candelabra	4W	40W	300	92.30%
S11243	B11	Medium	4W	40W	300	92.30%

PRODUCT DIMENSIONS

Item	MOL (A)	MOD (B)	Weight
S11240	5.51"	2.52"	0.10 Lbs.
S11241	4.33"	2.36"	0.08 Lbs.
S11242	4.72"	1.77"	0.07 Lbs.
S11243	4.25"	1.77"	0.06 Lbs.

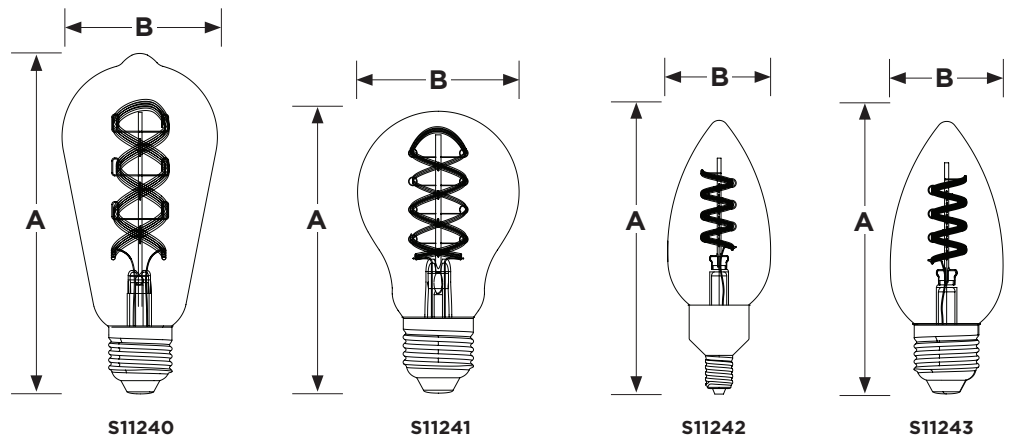

STARFISH®
live life enLightened

DOWNLOAD THE STARFISH APP



CONNECT
Download the STARFISH® app



INSTALL
Pair the smart products and configure settings



ENJOY
The convenience of unlimited features

This device complies with Part 15 of the FCC Rules. Operation is subject to the following two conditions: (1) this device may not cause harmful interference, and (2) this device must accept any interference received, including interference that may cause undesired operation.





WARNING: Some products included in this specification sheet may be subject to the warning requirements of California's Proposition 65. Please refer to your product packaging for more information.

Amazon, Alexa and all related logos are trademarks of Amazon.com, Inc. and its affiliates. Siri is a registered trademark of Apple Inc. Google, Google Play and Google Home are trademarks of Google LLC.

Visit satco.com/service/warranty for complete warranty details.

WI-FI LED RGB & TUNABLE WHITE BULBS

LED Color Changing and Tunable White bulbs replace standard medium base lamps with smart technology adding dynamic color changes and toning whites from warm-to-cool light.

-  **RGB Color**
-  **Tunable White, 80 or 90 CRI Ranging from 2200-5000K**
-  **Damp or wet location**
-  **Dimmable, with Starfish app**



WI-FI LED RGB & TUNABLE WHITE BULBS



ITEM	TYPE	CCT TECH	DIMENSIONS		WATTS	LUMENS	CRI	BASE	VOLTS	HRS	PACK	MASTER
			MOD (mm)	MOL (mm)								
Standard A19 Color Changeable & Tunable White												
S11252	A19	RGB/TW	2.36" (60)	4.57" (116)	9.5W	800	80	E26	120	25K	1pk Box	24
S11253	A19	RGB/TW	2.36" (60)	4.57" (116)	9.5W	800	80	E26	120	25K	2pk Box	24
S11254*	A19	RGB/TW	2.36" (60)	4.57" (116)	10W	800	90	E26	120	15K	1pk Box	24
S11275*	A19	RGB/TW	2.36" (60)	4.57" (116)	10W	800	90	E26	120	15K	2pk Box	24
S11287*	A21	RGB/TW	2.4" (61)	5.35" (135.9)	13W	1100	90	E26	120	15K	1pk Box	48
LED Filament Tunable White												
S11250**	A19	TW	2.36" (59.94)	4.33" (110)	5W	450	80	E26	120	15K	1pk Box	24
S11274**	A19	TW	2.36" (59.94)	4.33" (110)	7.5W	800	90	E26	120	15K	1pk Box	24
S11251**	G25	TW	3.15" (80.01)	4.45" (113.03)	4.5W	450	80	E26	120	15K	1pk Box	24
Directional Reflectors Color Changeable & Tunable White												
S11283	R20	RGB/TW	2.48" (63)	3.69" (93.7)	6W	480	90	E26	120	25K	1pk Box	24
S11255	BR30	RGB/TW	3.70" (94)	5.12" (130)	9.5W	800	80	E26	120	25K	1pk Box	12
S11256	BR30	RGB/TW	3.70" (94)	5.12" (130)	9.5W	800	80	E26	120	25K	2pk Box	12
S11257*	BR30	RGB/TW	3.70" (94)	5.12" (130)	9.5W	760	90	E26	120	25K	1pk Box	12
S11276*	BR30	RGB/TW	3.70" (94)	5.12" (130)	9.5W	760	90	E26	120	25K	2pk Box	12
S11284*	BR40	RGB/TW	4.72" (127)	6.42" (163.1)	12W	960	90	E26	120	25K	1pk Box	12
S11258	PAR38	RGB/TW	4.72" (127)	5.00" (127)	15W	1200	80	E26	120	25K	1pk Box	12
S11277*	PAR38	RGB/TW	4.72" (127)	5.00" (127)	15W	1200	90	E26	120	25K	1pk Box	12
S11271	MR16	RGB/TW	2.2" (56)	1.97" (50)	5.5W	400	80	GU10	120	25K	1pk Box	48
S11278	MR16	RGB/TW	2.2" (56)	1.97" (50)	5.5W	385	90	GU10	120	25K	1pk Box	48

** Not Energy Star *T20 Compliant

MOD = Diameter | MOL = Length

WI-FI 24' LED RGB & WARM WHITE 10-LIGHT OUTDOOR STRING LIGHT

Dimmable, long lasting and wet location certified, STARFISH™ plug-in string lights are portable and can be used indoors or out.



Durable black wire
 Connect up to 3 sets

- RGB Color**
- Wet location
- Warm White, 80 CRI 2700K
- Dimmable, with app

S11288,
 S11290,
 S11291



ITEM	CCT TECH	TYPE	DIMENSIONS			WATTS	CRI	VOLTS	HRS	PACK	MASTER
			LENGTH (mm)	WIDTH (mm)	HEIGHT (mm)						
S11288	RGB/TW	String Lights	24' (7315.2)	1.77" (45)	7.48" (190)	10W	80	120	15K	1 set Box	4
S11289		Replacement Bulb (S11288 Only)	-	1.77" (45)	3.46" (87.9)	1W	80	15K	2pk Card		12
S11290	RGB/TW	String Lights	24' (7315.2)	1.77" (45)	7.48" (190)	12W	-	120	15K	1 set Box	4
S11291	RGB/TW	String Lights	48' (14630.4)	1.77" (45)	7.48" (190)	15W	-	120	15K	1 set Box	4
S11292	TW	String Lights	24' (7315.2)	1.77" (45)	7.48" (190)	12W	-	120	15K	1 set Box	4
Accessories											
80-2812		6ft. Extension for S11288, 10W									

STARFISH™ WI-FI SMART SWITCHES & OUTLETS

Enable smart on-off or dimming control throughout a circuit utilizing STARFISH™ Wall and Dimmer Switches and Outlets.

- Dry location
- Dimmer Only
- Direct Wire, Neutral Wire required

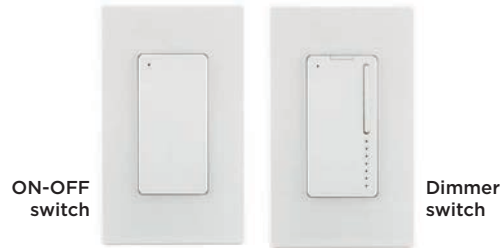

Enable smart on-off of small appliances with STARFISH™ plug-in outlets.

- Dry location
- Plug-in

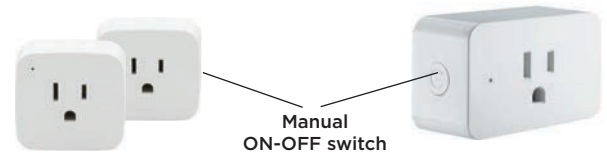

The rectangular Wi-Fi DIMMER outlet allows for on-off and dimming operation of lighting to a maximum of 300W of incandescent or 150W LED loads.

- Dry location
- Dimmable, with app
- Plug-in



STARFISH™ WI-FI SMART SWITCHES & OUTLETS

ITEM	TYPE	WIDTH (mm)	DIMENSIONS DEPTH (mm)	HEIGHT (mm)	AMPS	MOTOR	INC.	LED	VOLTAGE	PACK	MASTER
S11267	ON-OFF Switch	2.76" (70)	1.71" (43.43)	4.53" (115)	6A	3.6A	720W	720W	120V	1pk Box	12
S11268	Dimmer	2.76" (70)	1.71" (43.43)	4.53" (115)	N/A	N/A	450W	150W	120V	1pk Box	12
S11266	ON-OFF Outlet	2.87" (72.89)	1.69" (42.92)	1.97" (50.03)	15A	N/A	1800W	1800W	120V	1pk Box	12
S11269	Mini Square Plug-In Outlet	1.99" (50.54)	1.99" (50.54)	1.99" (50.54)	10A	N/A	1200W	1200W	120V	2pk Box	12
S11270	ON-OFF DIMMER Outlet	2.87" (72.89)	1.69" (42.92)	1.97" (50.03)	N/A	N/A	300W	150W	120V	1pk Box	12

SATCO DISTRIBUTION CENTERS

NEW YORK (HQ)
 110 HEARTLAND BLVD
 BRENTWOOD, NY 11717
 T. 631-243-2022
 F. 631-243-2027

TEXAS
 2000 VALWOOD PKWY
 FARMERS BRANCH, TX 75234
 T. 972-247-2437
 F. 972-247-5408

FLORIDA
 900 NW 159TH DR
 MIAMI, FL 33169
 T. 305-624-2044
 F. 305-623-0286

CALIFORNIA
 31288 SAN BENITO ST
 HAYWARD, CA 94544
 T. 510-487-4822
 F. 510-487-8955

WASHINGTON
 4710 116TH ST SW
 MUKILTEO, WA 98275
 T. 425-789-3300
 F. 425-789-3310

PUERTO RICO
 CAMPECHE STREET, 23
 JULIO N. MATOS INDUSTRIAL PARK
 CAROLINA, PR 00984
 T. 787-757-3510
 F. 787-757-3540

Products inventoried in Canada & Mexico, contact: internationalsales@satco.com / 631-243-2022 Ext. 315



STARFISH™

live life enlightened

STARFISH SMART LED INDOOR/OUTDOOR STRING LIGHTS

- Wi-Fi Enabled, multi-function system with infinite color options
- Mobile app or voice control
- Dimmable with app.**
- 12-15 Smart LED bulbs included
- Connect up to 144 Ft.†, 3 sets max.
- For residential and commercial use
- Heavy duty 18 gauge wire
- Easy installation and setup
- 3 Year warranty



voice control



set routines



remote access



create schedules



build scenes



secure



multi location



multi user



WIFI 2.4GHZ
NO HUB NEEDED



SEARCH FOR SATCO STARFISH IN THE APP STORE

COLOR CHANGEABLE

WARM TO COOL WHITE*



Item	Description	BULBS		FIXTURES						
		# Incl.	Watts/ Bulb	Connectible Units	CCT Selectable	W	V	Finish	UPC	M/Case Qty.
S11290	24FT/LED/SL/S14/SF/RGBW	12	1W	3	2700K-5000K	12	120	Black	045923112904	4
S11291	48FT/LED/SL/S14/SF/RGBW	15	1W	3	2700K-5000K	15	120	Black	045923112911	4
S11292*	24FT/LED/SL/S14/SF/TW	12 Frosted	1W	3	2700K-5000K	12	120	Black	045923112928	4

**Not compatible with in wall dimmers †144 Ft. is 3 sets of S11291



COUNTERQUICK™

LED Linkable Under Cabinet Fixture

**CCT SELECTABLE AND
STARFISH™ SMART RGBTW**





ENGINEERED FOR EASE OF INSTALLATION

SATCO|NUVO COUNTERQUICK™ Under Cabinet Fixtures were developed with a simple purpose— design a high quality under cabinet lighting solution that is easy to install.



WIRING MADE EASY

Professionals and seasoned DIYers alike will appreciate the ample internal wiring space for ease of installation. Optional under cabinet junction boxes offer even greater flexibility for retrofit applications or installations in tight areas. Use the cord and plug accessory when direct wiring isn't an option or if you want a simple update without a complete remodel.



KEEPING IT CLEAN

One power source is all that's needed for most applications, making for a clean installation. Optional extension cables in various lengths interconnect fixtures across large areas, around corners and between cabinets, eliminating the need for additional wiring to the power source or outlet.



GOING TO NEW LENGTHS

The included end-to-end wire connector allows you to mix and match various sizes and to configure customized lengths for any under cabinet installation.

WHAT'S IN THE BOX?



**63-511
END-TO-END
CONNECTOR**
(1 included with fixture)





Ample Wiring Space



**Concealed Direct Mount
Integrated Hardware**



**Keyhole Direct
Mounting Options**

**AVAILABLE IN BOTH CCT SELECTABLE
OR STARFISH™ SMART RGBTW**





LED SMART RGBTW



STARFISH™
live life enl:ghtened

DOWNLOAD THE
STARFISH APP



34"

28"

22"

14"

11"

**RGB COLOR-CHANGING AND
WARM-TO-COOL TUNABLE WHITE**

DIMMABLE VIA APP

WI-FI ENABLED NO HUB REQUIRED



voice control



remote access



build scenes



set routines



ITEM #	DESCRIPTION	WATTS	LUMENS	VOLTAGE	DIMENSIONS L x W x H	CONNECTION QTY
63-551	11" LED RGB Smart	6.5	450	120	11" x 3.5" x 1"	up to 72
63-552	14" LED RGB Smart	9	650	120	14" x 3.5" x 1"	up to 48
63-553	22" LED RGB Smart	13	920	120	22" x 3.5" x 1"	up to 36
63-554	28" LED RGB Smart	17	1350	120	28" x 3.5" x 1"	up to 22
63-555	34" LED RGB Smart	20	1500	120	34" x 3.5" x 1"	up to 18

Packing: 12/Master

ACCESSORIES FOR MORE WAYS TO CONNECT

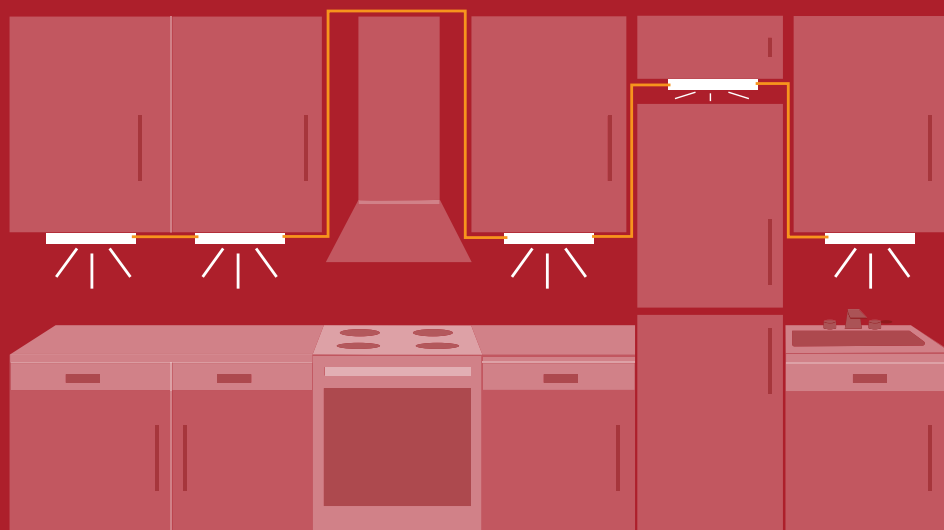

NO JOB IS TOO BIG FOR COUNTERQUICK

Configure up to 22 of the 28" fixtures and up to 96 of the 8" fixtures. Custom installations are possible by mixing different lengths using a combination of link cables, junction boxes and end-to-end connectors.



63-513
PLASTIC JUNCTION BOX with
3/8" WIRE CONNECTOR (63-512)



63-515 (6")
63-516 (12")
63-517(24")
LINK CABLE



63-518
MALE-TO-FEMALE
LINK CONNECTOR



63-514
METAL
JUNCTION BOX



63-510
POWER
CORD

ITEM #	DESCRIPTION	DIMENSIONS	MASTER	PACKAGE
63-510	Power Cord	60" Length	96	Polybag
63-511*	End-to-End Connector (Included)	1" Length	96	Polybag
63-512	3/8" Wire Connector (Attached to Junction Box)	1.5" x 0.67" x 0.35"	96	Polybag
63-513	Junction Box - Plastic	4" x 2" x 1"	48	Box
63-514	Junction Box - Metal	4" x 2" 1"	48	Box
63-515	Link Cable 6"	6" Length	96	Polybag
63-516	Link Cable 12"	12" Length	96	Polybag
63-517	Link Cable 24"	24" Length	96	Polybag
63-518	Cable Link Connector	3" Length	96	Polybag

*Included End-to-End Connector can be reordered if needed



DIMENSION™

Indoor & Outdoor LED Tape Light Kits

DIMENSION PRO

INDOOR LED SMART TAPE LIGHT KIT



STARFISH™
Controlled with App



**STARFISH™ SMART
ENABLED PRODUCT**

**DYNAMIC RGB,
COLOR-CHANGING
& TUNABLE WHITE**

**PRE-SET & CUSTOM
COLOR-CHANGING EFFECTS**

**IR REMOTE CONTROL
OR APP CONTROLLED**

**16FT, 32FT & 64FT
KITS AVAILABLE**

**PLUG-IN OR
DIRECT-WIRE KITS**

CUTTABLE

SUGGESTED APPLICATIONS:
Commercial or Decorative
Residential Applications

HIGH BRIGHTNESS



Millions of Colors



Warm to Cool Tunable White

Immerse yourself in a world of limitless possibilities with DIMENSION Pro, the smart app-controlled tape light that will redefine your lighting experience. With the ability to choose from millions of colors or adjust the light from warm to cool tunable white, this STARFISH™ smart product puts the power of customization in your hands. Sync your light to the rhythm of your favorite music and watch as your space comes alive with vibrant hues and captivating effects. From soothing transitions to dynamic color-changing displays, DIMENSION Pro offers a wide range of mesmerizing options that will transform your space into a visual spectacle.

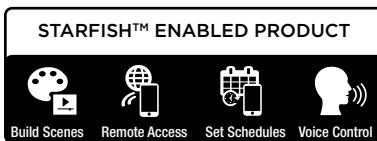

*Via App or Remote



GENERAL SPECIFICATIONS

Color: RGBTW

CRI: 80

Functional Life: 50,000 Hours

Location Rating: Dry (Indoor Only)

Wired Controller: Yes

Ambient Operating Temperature: -20°C (-4°F) to +40°C (+104°F)

Cuttable: Yes*, Distance between cuts: 4.92" (125mm)

Dimmable: Yes, Dimmable with App or Remote

Warranty: 1 Year

Remote: IR

* Tape may be cut where indicated for customized installations. Cut tape can be reconnected using optional connector accessories. Total tape length should not exceed the tape supplied in the kit.



ITEM SPECIFICATIONS / ORDER INFO

Item	Length	Style	Input Voltage	DC Voltage	Watts	Lumens	Number of Reels	UPC
64/130	16'	Plug In	120V	24V	18W	1920L	1	045923640292
64/131	32'	Plug In	120V	24V	30W	3080L	1	045923640308
64/132	64'	Plug In	120V	24V	68W	6300L	2	045923640520
64/133	16'	Direct Wired	120V-277V	24V	20W	1920L	1	045923640537
64/134	32'	Direct Wired	120V-277V	24V	30W	3080L	1	045923640544
64/135	64'	Direct Wired	120V-277V	24V	68W	6300L	2	045923640551

ACCESSORIES INCLUDED IN KITS



Plug-In Driver



Direct Wire Junction Box
64/133 Includes 5, 3/8 Knockouts
64/134 Includes 5, 3/8 Knockouts
64/135 Includes 7, 3/8 Knockouts



Controller/Receiver



Dual Controller/Receiver
For Models 64/132 and 64/135



IR Remote



Single Reel for
64/130, 64/131, 64/133, and 64/134



Dual Reel for
64/132 and 64/135 Kits

This device complies with Part 15 of the FCC Rules. Operation is subject to the following two conditions: (1) this device may not cause harmful interference, and (2) this device must accept any interference received, including interference that may cause undesired operation. Fixture may not be compatible with all dimmers.

Specifications are subject to change without prior notice.

DIMENSION PRO

OUTDOOR LED SMART TAPE LIGHT KIT



STARFISH™
Controlled with App



**STARFISH™ SMART
ENABLED PRODUCT**

**DYNAMIC RGB,
COLOR-CHANGING
& TUNABLE WHITE**

**PRE-SET & CUSTOM
COLOR-CHANGING EFFECTS**

**RF REMOTE CONTROL OR
APP CONTROLLED**

**16FT, 32FT & 64FT
KITS AVAILABLE**

**PLUG-IN OR
DIRECT-WIRE KITS**

SUGGESTED APPLICATIONS:

Outdoor Commercial or
Decorative Outdoor
Residential Applications

HIGH BRIGHTNESS



Millions of Colors



Warm to Cool Tunable White

Elevate your outdoor space with DIMENSION Pro Outdoor tape light kits. This smart, app-controlled lighting solution offers limitless customization. Choose from millions of colors and adjust the light from warm to cool tunable white. Sync it with your music for vibrant and captivating effects. With mesmerizing options, DIMENSION Pro transforms your outdoor area into a visual spectacle.

STARFISH™ ENABLED PRODUCT

Build Scenes Remote Access Set Schedules Voice Control **WIFI** 2.4GHz No Hub Required



*Via App or Remote

GENERAL SPECIFICATIONS

Color: RGBTW
CRI: 80
Functional Life: 50,000 Hours
Location Rating: Wet
Wired Controller: No

Ambient Operating Temperature: -20°C (-4°F) to +40°C (+104°F)
Cuttable: Not Cuttable*
Dimmable: Yes, Dimmable with App or Remote
Warranty: 1 Year
Remote: RF

* Outdoor tape light is not recommended to be cut. Cutting tape invalidates the IP65 rating and warranty.

ITEM SPECIFICATIONS / ORDER INFO



Item	Length	Style	Input Voltage	DC Voltage	Watts	Lumens	Number of Reels	UPC
64/140	16'	Plug In	120V	24V	18W	1920L	1	045923640568
64/141	32'	Plug In	120V	24V	30W	3080L	1	045923640575
64/142	64'	Plug In	120V	24V	68W	6300L	2	045923640582
64/143	16'	Direct Wired	120V-277V	24V	20W	1920L	1	045923640599
64/144	32'	Direct Wired	120V-277V	24V	33W	3080L	1	045923640605
64/145	64'	Direct Wired	120V-277V	24V	68W	6300L	2	045923640506

INCLUDED ACCESSORIES



Plug-In Driver



Direct Wire Junction Box
 64/143 Includes 5, 3/8 Knockouts
 64/144 Includes 5, 3/8 Knockouts
 64/145 Includes 7, 3/8 Knockouts



Mounting Clips



Receiver



RF Remote



Single Reel for
 64/140, 64/141, 64/143, and 64/144 Kits



Dual Reel for
 64/142 and 64/145 Kits



Dual Receiver
 For Models 64/142 and 64/145

OPTIONAL ACCESSORIES



Mounting
 Clip Pack

This device complies with Part 15 of the FCC Rules. Operation is subject to the following two conditions: (1) this device may not cause harmful interference, and (2) this device must accept any interference received, including interference that may cause undesired operation. Fixture may not be compatible with all dimmers.

Specifications are subject to change without prior notice.

DIMENSION PLUS

INDOOR LED SMART TAPE LIGHT KIT



STARFISH™
Controlled with App



**STARFISH™ SMART
ENABLED PRODUCT**

**DYNAMIC RGB,
COLOR-CHANGING
& TUNABLE WHITE**

**PRE-SET & CUSTOM
COLOR-CHANGING EFFECTS**

**IR REMOTE CONTROL
OR APP CONTROLLED**

16FT KITS AVAILABLE

**PLUG-IN OR
DIRECT-WIRE KITS**

CUTTABLE

SUGGESTED APPLICATIONS:
Commercial or Decorative
Residential Applications

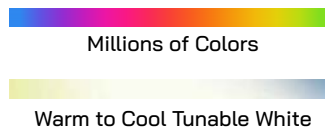

Unlock a world of possibilities with DIMENSION Plus, the versatile tape light designed for residential lighting and more. Choose from millions of vibrant colors or create the perfect ambiance. Sync the lighting to your favorite soundtrack and elevate your gaming experience or transform your living space. With its user-friendly features and top-notch quality, DIMENSION Plus brings a touch of magic to any setting.



*Via App or Remote



GENERAL SPECIFICATIONS

Color: RGBTW

CRI: 80

Functional Life: 50,000 Hours

Location Rating: Dry (Indoor Only)

Wired Controller: Yes

Ambient Operating Temperature: -20°C (-4°F) to +40°C (+104°F)

Cuttable: Yes*, Distance between cuts: 6.56" (166.67mm)

Dimmable: Yes, Dimmable with App or Remote

Warranty: 1 Year

Remote: IR

* Tape may be cut where indicated for customized installations. Cut tape can be reconnected using optional connector accessories. Total tape length should not exceed the tape supplied in the kit.



ITEM SPECIFICATIONS / ORDER INFO

Item	Length	Style	Input Voltage	DC Voltage	Watts	Lumens	Number of Reels	UPC
64-120	16'	Plug In	120V	24V	12W	1120L	1	045923640278
64-121	16'	Direct Wired	120V-277V	24V	14W	1120L	1	045923640285

ACCESSORIES INCLUDED IN KITS



Plug-In Driver



Direct Wire Junction Box - 5, 3/8" Knockouts



Controller/Receiver



IR Remote



Single Reel for 64/120 and 64/121 Kits

This device complies with Part 15 of the FCC Rules. Operation is subject to the following two conditions: (1) this device may not cause harmful interference, and (2) this device must accept any interference received, including interference that may cause undesired operation. Fixture may not be compatible with all dimmers.

Specifications are subject to change without prior notice.

OPTIONAL ACCESSORIES

Item	Description	Qty/Bag or Box	Bag or Box/Case	UPC
Tape Extension and Connectors				
Tape to Tape				
64/160	Tape-to-Tape Connector	5	100	045923644788
64/161	6" Jumper Wire	5	100	045923644795
64/162	90° Connector	5	100	045923644801
Wire to Tape				
64/164	Wire to Tape Connector	6	100	045923644177
64/165	50' Tape Wire	1	50	045923644184

Item	Description	Length/Channel	Channel/Box	Channel Sets/Case	UPC
Channels and Diffusers					
Recessed					
64/150	Recessed Deep Channel and Diffuser	3.28'	5	12	045923644733
Surface					
64/151	Deep Channel and Diffuser	3.28'	5	12	045923644740
64/154	Shallow Channel and Diffuser	3.28'	5	12	045923644771
Corner					
64/152	45° Corner Channel and Diffuser	3.28'	5	12	045923644757



64-164



64-160



64-165



64-162



64-161



64-154



64-152



64-151



64-150

This device complies with Part 15 of the FCC Rules. Operation is subject to the following two conditions: (1) this device may not cause harmful interference, and (2) this device must accept any interference received, including interference that may cause undesired operation. Fixture may not be compatible with all dimmers.

Specifications are subject to change without prior notice.



STARFISH™
live life enlightened



SMART LED SECURITY FLOODLIGHT CAMERA

1080P HD CAMERA
WITH 150° VIEWING ANGLE

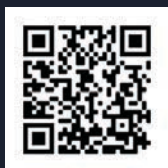

Learn More

SATCO | **NUVO**

SECURITY WITHOUT A SUBSCRIPTION

SATCO's Security Floodlight Camera offers the latest technology in home security and surveillance without the monthly subscription fees associated with competing products.

When motion is detected, the 1080p HD camera records events and stores them directly to the devices included 32GB microSD card. Live and recorded events can instantly be viewed on any mobile device using the STARFISH™ app, anywhere, any time.



NO MONTHLY SUBSCRIPTION

REAL-TIME MOTION EVENTS

VIDEO HISTORY & NIGHT VISION

REMOTE ACCESS

ADJUSTABLE LED FLOODLIGHTS

270° MOTION DETECTION

20W - 1900 LUMENS - 3000K

IP65 WEATHERPROOF DESIGN

50,000 HOURS

5 YEAR WARRANTY



NO MONTHLY SUBSCRIPTION

Access video content on included 32G microSD Card (expandable to 128G)



REAL-TIME MOTION EVENTS

Get real-time notifications when motion is detected around your home



VIDEO HISTORY

Check your motion recording history to see activity while you're away

A WHOLE HOME SMART SOLUTION

STARFISH™ is a leading technology that combines smart home security and lighting controls into one complete solution. With a growing line of security and lighting products, SATCO's STARFISH products are the premier choice in building your smart home—all controlled by a single app.

20 WATTS TOTAL

3000K CCT, 1900 TOTAL LUMENS
FLOODLIGHTS 50,000 HOURS
RATED LIFE

CONTROL

FLOODLIGHTS CAN BE
CONTROLLED OR DIMMED
THROUGH STARFISH™ APP

**RETROFIT EXISTING
FLOODLIGHTS**
IN RECESSED AND SURFACE
MOUNT JUNCTION BOXES

**ADJUSTABLE HEADS
AND CAMERA**
FOR OPTIMAL PERFORMANCE

1080p HD
150° VIEWING ANGLE
HD CAMERA

IP65
WEATHERPROOF DESIGN

IR NIGHT VISION

LOCAL STORAGE
LOCAL STORAGE WITH UP TO 128GB
MICRO SD CARD (32GB INCLUDED)

2-WAY TALK

ADVANCED MOTION DETECTION
270° INFRARED PIR SENSOR

65/901
Black

65/900
White

65/902
Brown



2-way
talk



remote
access



night
vision



AWS secure
encryption



dimmable
with app



siren

SMART LED SECURITY FLOODLIGHT CAMERA

1080P HD CAMERA WITH 150° VIEWING ANGLE



ADVANCED MOTION DETECTION

Set motion zones and sensitivity of mobile alerts



HD VIDEO

1080p high definition security camera with 2-way talk



NIGHT VISION

Integrated infrared lights allow viewing in low lit areas



For an in-depth exploration of STARFISH™ features including the latest products, visit SATCOSTARFISH.COM



Visit Website



Mobile App



ITEM	DESCRIPTION	W	V	DIMENSIONS	UPC
65-900	SECURITY LIGHT CAMERA - WHITE	20W	120-277V	W 7.6 x H 10.04	045923659683
65-901	SECURITY LIGHT CAMERA - BLACK	20W	120-277V	W 7.6 x H 10.04	045923659690
65-902	SECURITY LIGHT CAMERA - BROWN	20W	120-277V	W 7.6 x H 10.04	045923659706

SATCO DISTRIBUTION CENTERS

NEW YORK (HQ)
110 HEARTLAND BLVD
BRENTWOOD, NY 11717
T. 631-243-2022
F. 631-243-2027

TEXAS
2000 VALWOOD PKWY
FARMERS BRANCH, TX 75234
T. 972-247-2437
F. 972-247-5408

FLORIDA
1694 NW 215TH ST
MIAMI GARDENS, FL 33056
T. 305-624-2044
F. 305-623-0286

CALIFORNIA
31288 SAN BENITO ST
HAYWARD, CA 94544
T. 510-487-4822
F. 510-487-8955

WASHINGTON
4710 116TH ST SW
MUKILTEO, WA 98275
T. 425-789-3300
F. 425-789-3310

PUERTO RICO
CAMPECHE STREET, 23
JULIO N. MATOS INDUSTRIAL PARK
CAROLINA, PR 00984
T. 787-757-3510
F. 787-757-3540

For International Sales, contact: internationalsales@satco.com /631-243-2022 Ext. 315

SMART LED SECURITY LIGHT & CAMERA RECTANGLE HEADS



STARFISH
live life enlightened

ADJUSTABLE RECTANGULAR
HIGH-LUMEN LIGHT HEADS

REAL-TIME MOTION ALERTS
AND VIDEO HISTORY

1080P HD CAMERA WITH
NIGHT VISION

REMOTE VIEWING AND
TWO-WAY TALK

INTEGRATED SECURITY SIREN

OFFERED IN WHITE AND
BLACK FINISHES

SUGGESTED APPLICATIONS

Residential, Multifamily,
Hospitality, Commercial

SATCO|NUVO's Smart Security Flood Lights with Camera offers the latest technology in home security and surveillance. Tunable white flood lights provide illumination when it's needed most. View live and event history remotely from any mobile device with the STARFISH® app anywhere, any time. These energy efficient smart fixtures are also compatible with Siri, Alexa, and Google Home so they can be easily incorporated into your smart home.

- NO MONTHLY SUBSCRIPTION**
- WET LOCATION**
- IP 65**
- DIMMABLE WITH APP**
- 50,000 HOURS**
- 3 YEAR WARRANTY**
- TRUSTED NB WARRANTY**

STARFISH' ENABLED PRODUCT

- Night Vision
- Remote Access
- Multi-User
- AWS Secure

WIFI
2.4GHz
No Hub Required

works with **alexa**

works with **Google Home**

Add to Siri

GENERAL SPECIFICATIONS

Input Voltage, Frequency: 120V-277V, 50-60Hz
Tunable White CCT: 3000K-5000K with STARFISH® app
Dimmable: Down to 10% with STARFISH® app
CRI: 80
Efficacy: up to 125 LPW
Functional Life: 50,000 Hours
IP Rating: IP65
Location Rating: Wet
Ambient Operating Temperature: -20°C (-4°F) to +45°C (+113°F)

Body Construction: Aluminum
Lens Construction: Polycarbonate
Camera Construction: Plastic
Mounting Options: Wall/Eave Mounts to Standard Surface or Recessed J-Box
Camera: 1080P, 100° viewing angle
Memory Card: 32GB SD Card included (upgradeable to 128GB)
Warranty: 3 Years

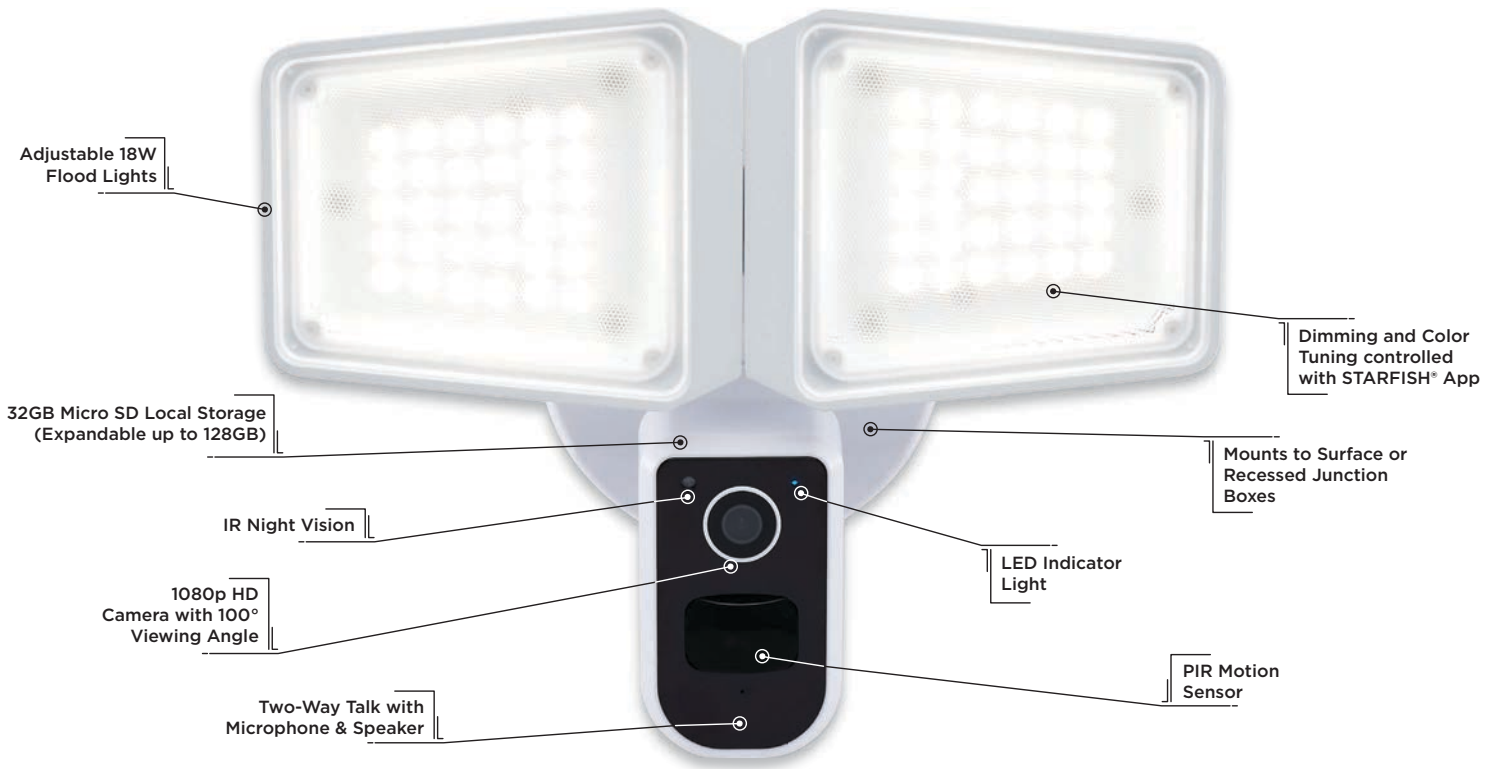

DOWNLOAD THE STARFISH APP



CONNECT
Download the STARFISH® app

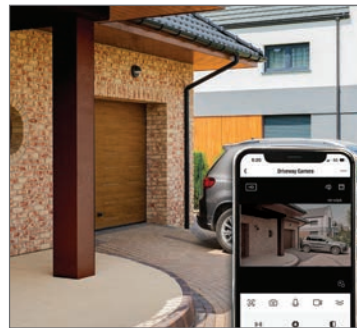

INSTALL
Pair and configure your settings



ENJOY
The convenience and customization of smart lighting

This device complies with Part 15 of the FCC Rules. Operation is subject to the following two conditions: (1) this device may not cause harmful interference, and (2) this device must accept any interference received, including interference that may cause undesired operation.

WARNING: Some products included in this specification sheet may be subject to the warning requirements of California's Proposition 65. Please refer to your product packaging for more information.

Amazon, Alexa and all related logos are trademarks of Amazon.com, Inc. and its affiliates. Siri is a registered trademark of Apple Inc. Google, Google Play and Google Home are trademarks of Google LLC.

Visit satco.com/service/warranty for complete warranty details.



ITEM SPECIFICATIONS/ORDERING INFO

Item	Description	Lumens	Wattage	Replacement Wattage	Width (A)	Height (B)	Extends (C)	Weight
65-920	White	4500	36W	200W	9.80"	7.05"	6.00"	1.65 Lbs.
65-921	Black	4500	36W	200W	9.80"	7.05"	6.00"	1.65 Lbs.

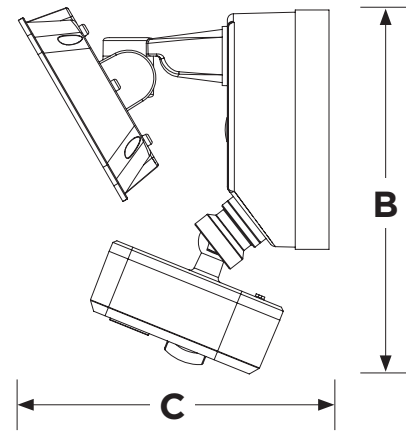
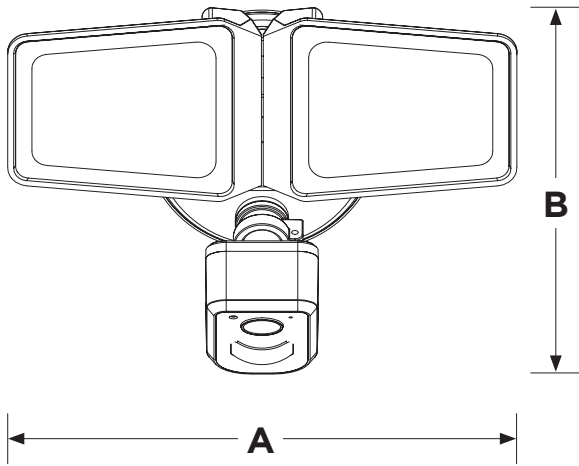

SMART LED SECURITY LIGHT & CAMERA BULLET HEADS



STARFISH
live life enlightened

3-CCT SELECTABLE

ADJUSTABLE BULLET
HIGH-LUMEN LIGHT HEADS

REAL-TIME MOTION ALERTS
AND VIDEO HISTORY

1080P HD CAMERA WITH
NIGHT VISION

REMOTE VIEWING AND
TWO-WAY TALK

INTEGRATED SECURITY SIREN

OFFERED IN WHITE AND
BLACK FINISHES

SUGGESTED APPLICATIONS
Residential, Multifamily,
Hospitality, Commercial

SATCO|NUVO's Smart Security Flood Lights with Camera offers the latest technology in home security and surveillance. CCT selectable flood lights provide illumination when it's needed most. View live and event history remotely from any mobile device with the STARFISH® app anywhere, any time. These energy efficient smart fixtures are also compatible with Google Home, Alexa, and Siri so they can be easily incorporated into your smart home.

- NO MONTHLY SUBSCRIPTION**
- WET LOCATION**
- IP 65**
- DIMMABLE WITH APP**
- 50,000 HOURS**
- 3 YEAR WARRANTY**
- TRUSTED NB WARRANTY**

STARFISH® ENABLED PRODUCT

- Night Vision
- Remote Access
- Multi-User
- AWS Secure

WIFI
2.4GHz
No Hub Required

works with **alexa**

works with **Google Home**

Add to Siri

GENERAL SPECIFICATIONS

Input Voltage, Frequency: 120V-277V, 50-60Hz
CCT Selectable: 3000K/4000K/5000K
Dimmable: Down to 10% with STARFISH® app
CRI: 80
Efficacy: up to 87 LPW
Functional Life: 50,000 Hours
IP Rating: IP65
Location Rating: Wet
Ambient Operating Temperature: -20°C (-4°F) to +45°C (+113°F)

Body Construction: Aluminum
Lens Construction: Polycarbonate
Camera Construction: Plastic
Mounting Options: Wall/Eave Mounts to Standard Surface or Recessed J-Box
Camera: 1080P, 100° viewing angle
Memory Card: 32GB SD Card included (upgradeable to 128GB)
Warranty: 3 Years

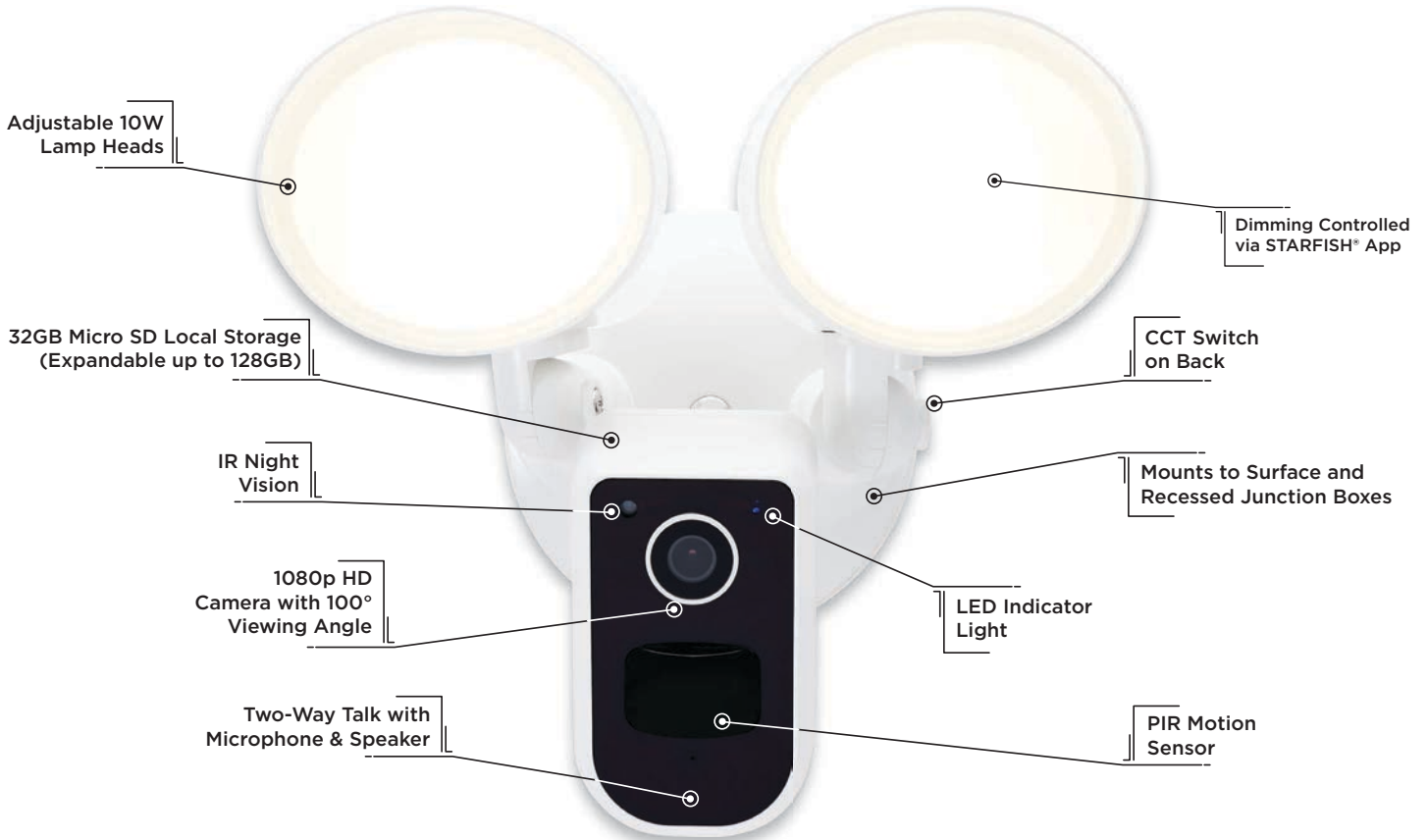

DOWNLOAD THE STARFISH APP



CONNECT
Download the STARFISH™ app



INSTALL
Pair and configure your settings



ENJOY
The convenience and customization of smart lighting

This device complies with Part 15 of the FCC Rules. Operation is subject to the following two conditions: (1) this device may not cause harmful interference, and (2) this device must accept any interference received, including interference that may cause undesired operation.

WARNING: Some products included in this specification sheet may be subject to the warning requirements of California's Proposition 65. Please refer to your product packaging for more information.

Amazon, Alexa and all related logos are trademarks of Amazon.com, Inc. and its affiliates. Siri is a registered trademark of Apple Inc. Google, Google Play and Google Home are trademarks of Google LLC.

Visit satco.com/service/warranty for complete warranty details.



ITEM SPECIFICATIONS/ORDERING INFO

Item	Description	Max Lumens	Wattage	Replacement Wattage	Width (A)	Height (B)	Extension (C)	Weight
65-930	White	1750	20W	100W	8.60"	6.31"	7.32"	1.43 Lbs.
65-931	Black	1750	20W	100W	8.60"	6.31"	7.32"	1.43 Lbs.

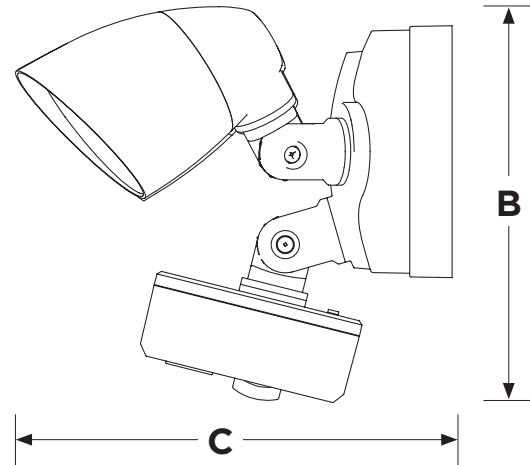
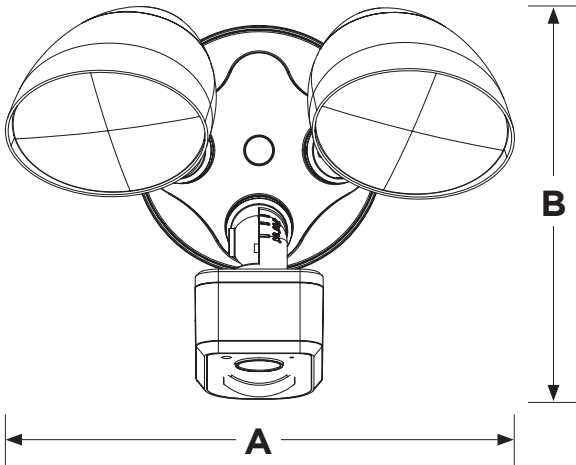

SMART WIRELESS VIDEO DOORBELL WITH REMOTE CHIME



STARFISH
live life enlightened

COMPLETE DOORBELL SYSTEM

SIMPLE WIRELESS
INSTALLATION

RECHARGEABLE BATTERY

REMOTE VIEWING AND
TWO-WAY TALK

LIVE AND EVENT HISTORY
MONITORING

EXPANDABLE MICRO SD CARD
STORAGE

Easily expand home security with SATCO|NUVO's Smart Wireless Doorbell with Remote Chime. This complete doorbell system comes with rechargeable battery so that the unit can be installed with no electrical work. Motion detection sends alerts directly to your mobile device allowing you to view historical events and live events in real time, from anywhere. The included chime plugs into standard 120V outlets, making the doorbell audible, even if your mobile is on silent.

**NO MONTHLY
SUBSCRIPTION**

WET
LOCATION

**IP
65**

**1 YEAR
WARRANTY**

**TRUSTED
NB
WARRANTY**

BATTERY
OPERATED

STARFISH' ENABLED PRODUCT

Night Vision
 Remote Access
 Multi-User
 AWS Secure

**WIFI
2.4GHz
No Hub Required**

works with
Google Home

works with
alexa

Add to Siri

Works with
SmartThings

GENERAL SPECIFICATIONS

Input Voltage, Frequency: WiFi: 2.4GHz
Camera Resolution: 1080p
Field of View: 140° Diagonal
Local Storage:
 32GB SD Card Included (Expandable up to 128GB)
Battery Type: 5000mAh Rechargeable

Rechargeable Battery:
 Lasts 4-6 Months with Average 10 Daily Activations
Operating Temperature: -20°C (-4°F) to +45°C (+113°F)
Location Rating: IP65 Rated for use in Wet Locations

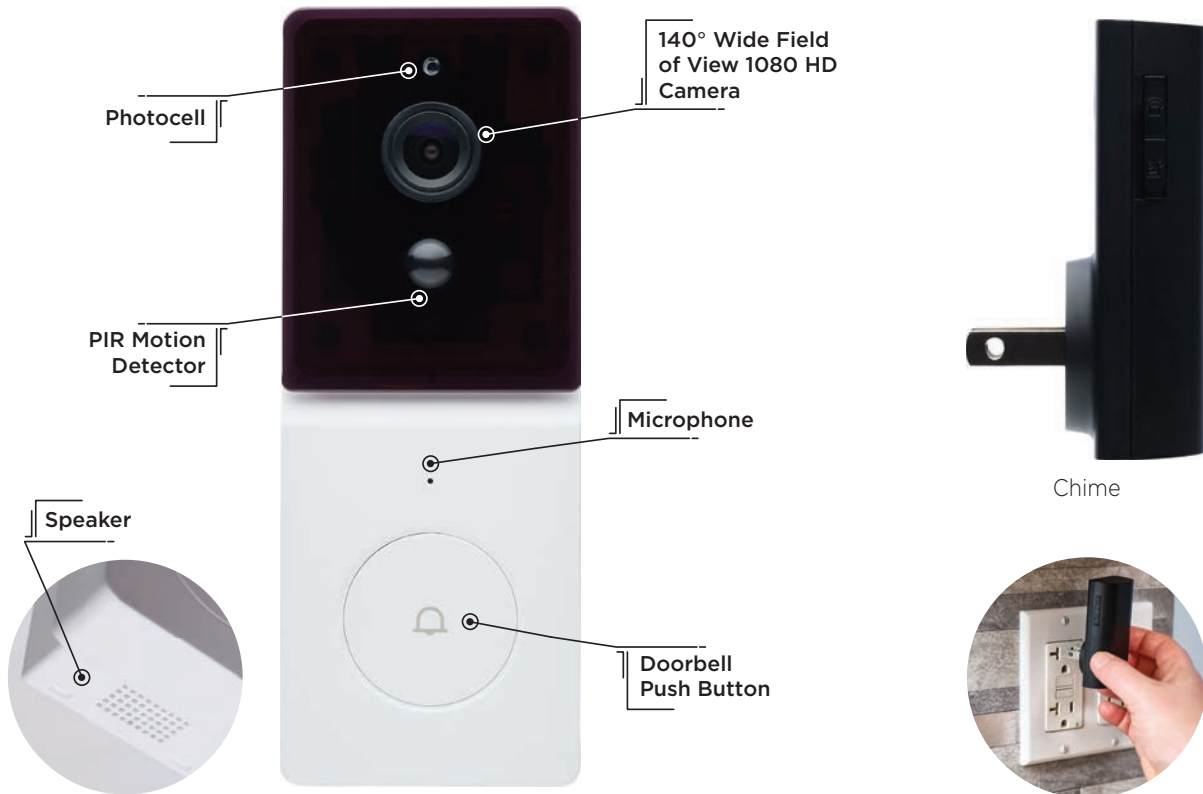

DOWNLOAD THE STARFISH APP



CONNECT
Download the STARFISH® app



INSTALL
Pair and configure your settings



ENJOY
The convenience and customization of smart lighting

This device complies with Part 15 of the FCC Rules. Operation is subject to the following two conditions: (1) this device may not cause harmful interference, and (2) this device must accept any interference received, including interference that may cause undesired operation.

WARNING: Some products included in this specification sheet may be subject to the warning requirements of California's Proposition 65. Please refer to your product packaging for more information.

Amazon, Alexa and all related logos are trademarks of Amazon.com, Inc. and its affiliates. Siri is a registered trademark of Apple Inc. Google, Google Play and Google Home are trademarks of Google LLC.

SATCO.COM | 800-437-2826

© Satco Products, Inc. All rights reserved. Rev. 4/24 SN1640



ITEM SPECIFICATIONS/ORDERING INFO

Item	Finish	Chime Finish	Width (A)	Height (B)	Extends (C)	Weight
65-935	White	Black	2.09"	5.45"	1.19"	0.45 Lbs.
65-936	Black	Black	2.09"	5.45"	1.19"	0.45 Lbs.

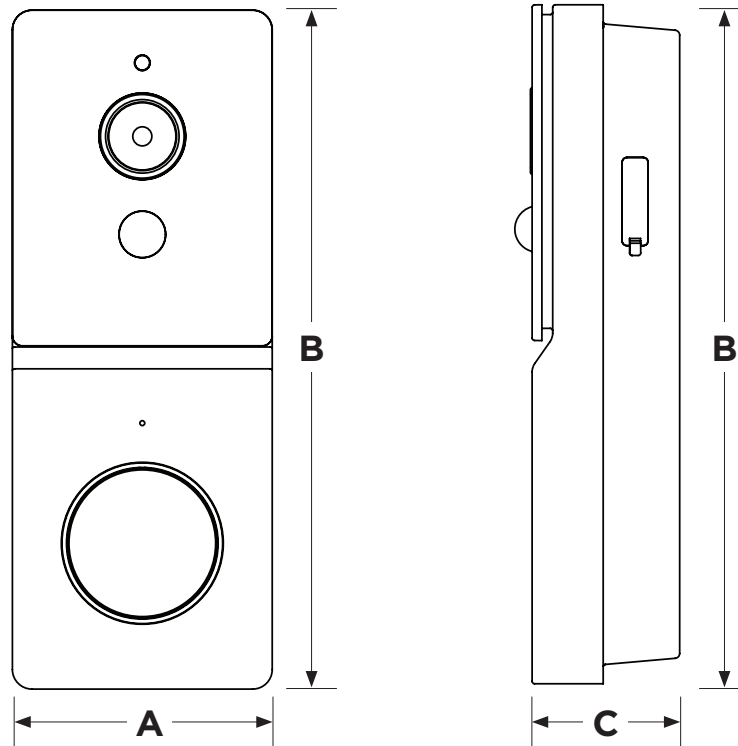

SMART OUTDOOR PAN & TILT CAMERA WHITE FINISH



STARFISH
live life enlightened

Easily expand home security with SATCO|NUVO's Smart Outdoor Pan and Tilt Camera. Easily mount to siding or eaves to view any outdoor space. Use the app to adjust the viewing angle panning 310° and tilting up to 130°. View real-time or review motion activated events from anywhere on your mobile device with the STARFISH® app. Discreetly listen in or actively engage in conversation with the two-way talk feature. Best of all, no subscription fees, ever.

This camera is also compatible with Google Home, Siri, SmartThings, and Alexa, including the Alexa Show.

- 

- SIMPLE PLUG & PLAY
INSTALLATION**

- 3MP CAMERA**

- ADJUST CAMERA POSITION
AND VIEWING ANGLE VIA APP**

- REMOTE VIEWING AND
TWO-WAY TALK**

- LIVE AND EVENT HISTORY
MONITORING**

- EXPANDABLE MICRO SD
CARD STORAGE**

**NO MONTHLY
SUBSCRIPTION**



STARFISH' ENABLED PRODUCT

Night Vision

Remote Access

Multi-User

AWS Secure

WIFI
2.4GHz
No Hub Required



GENERAL SPECIFICATIONS

WiFi Frequency: 2.4GHz
Camera Resolution: 1296P (3MP)
Field of View: 110° Diagonal / 96° High
Rotation Angle: Pan 310°, Tilt 130°
LED Lights: 400 Lumens, 6,000K
Local Storage:
 32GB SD Card Included (Expandable up to 128GB)
Finish: White

Location Rating: Wet
IP Rating: IP65
Operating Temperature: -10°C (+14°F) to +50°C (+122°F)
Mounting Options: Ceiling/Wall
Includes: Smart Camera, Mounting Bracket, Plug-In Cable, Wall Screws, Quick Start Guide
Warranty: 1 Year

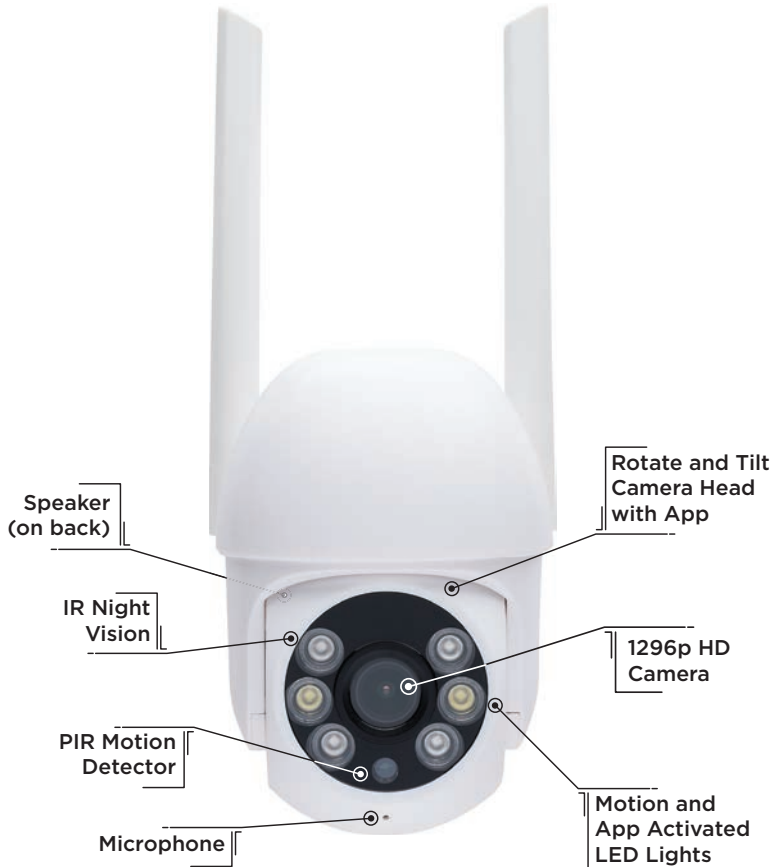

Mounting Bracket and Wall Screws



Plug-In Cable



DOWNLOAD THE STARFISH APP



CONNECT
Download the STARFISH® app

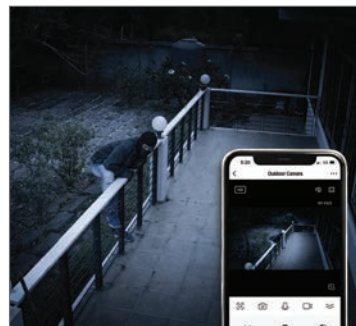

INSTALL
Pair and configure your settings



ENJOY
The convenience and customization of smart lighting

This device complies with Part 15 of the FCC Rules. Operation is subject to the following two conditions: (1) this device may not cause harmful interference, and (2) this device must accept any interference received, including interference that may cause undesired operation.

WARNING: Some products included in this specification sheet may be subject to the warning requirements of California's Proposition 65. Please refer to your product packaging for more information.

Amazon, Alexa and all related logos are trademarks of Amazon.com, Inc. and its affiliates. Siri is a registered trademark of Apple Inc. Google, Google Play and Google Home are trademarks of Google LLC.

Visit satco.com/service/warranty for complete warranty details.



ITEM SPECIFICATIONS/ORDERING INFO

Item	Finish	Height (A)	Diameter (B)	Extends (C)	Weight
65-925	White	4.43"	3.09"	3.75"	0.6 Lbs.

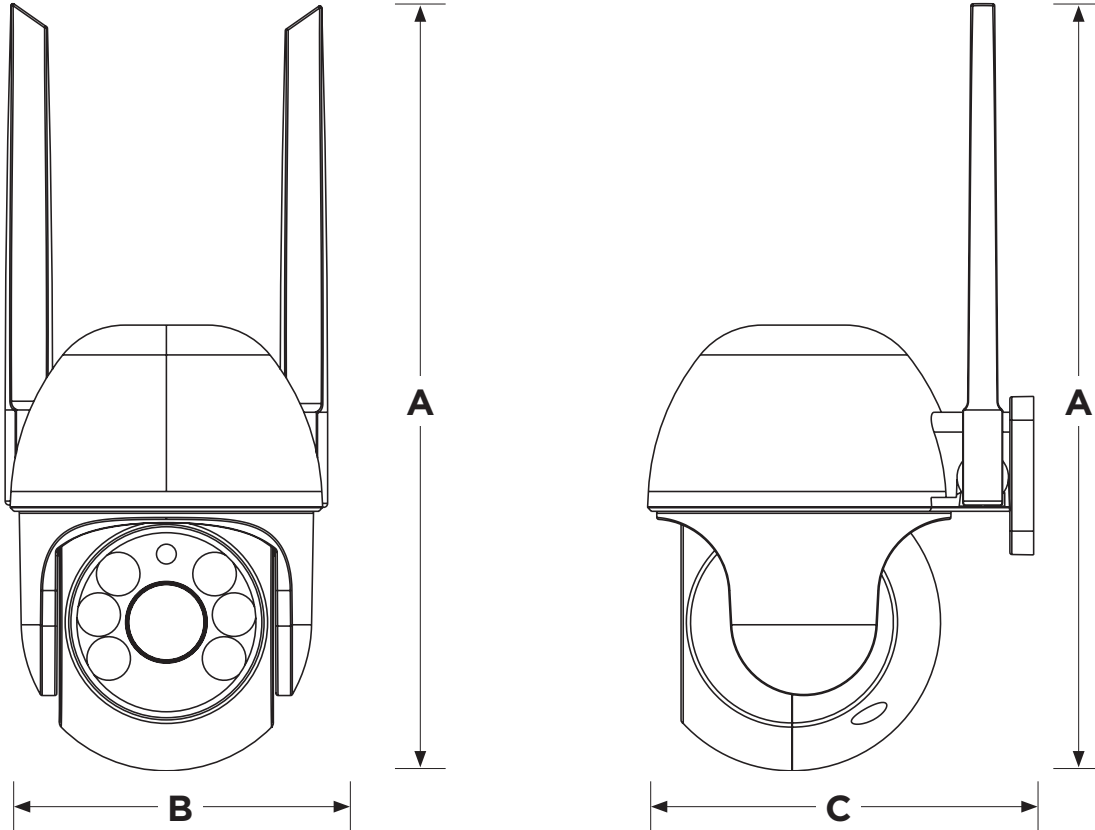

SMART INDOOR PAN & TILT CAMERA WHITE FINISH



STARFISH
live life enlightened

Easily expand home security with SATCO|NUVO's Smart Indoor Pan and Tilt Camera. Easily mount to the ceiling or wall to view any indoor space. Use the app to adjust the viewing angle panning 345° and tilting -10° to 40° . View real-time or review motion activated events from anywhere on your mobile device with the STARFISH® app. Discreetly listen in or actively engage in conversation with the two-way talk feature. Best of all, no subscription fees, ever.

This camera is also compatible with Google Home, Siri, SmartThings, and Alexa, including the Alexa Show.



**SIMPLE PLUG & PLAY
INSTALLATION**

**ADJUST VIEWING ANGLE
VIA APP**

**REMOTE VIEWING AND
TWO-WAY TALK**

**LIVE AND EVENT HISTORY
MONITORING**

**EXPANDABLE MICRO SD
CARD STORAGE**

**NO MONTHLY
SUBSCRIPTION**



STARFISH' ENABLED PRODUCT



WIFI
2.4GHz
No Hub Required



GENERAL SPECIFICATIONS

WiFi Frequency: 2.4GHz
Camera Resolution: 1080p
Field of View: 93° Diagonal
Rotation Angle: Pan 345°, Tilt -10° - 40°
Local Storage:
 32GB SD Card Included (Expandable up to 128GB)

Finish: White
Operating Temperature:
 -10°C (+14°F) to +45°C (+113°F)
Installation: Includes Mounting Base for fixed placement,
 Ceiling or Wall hanging.
Warranty: 1 Year

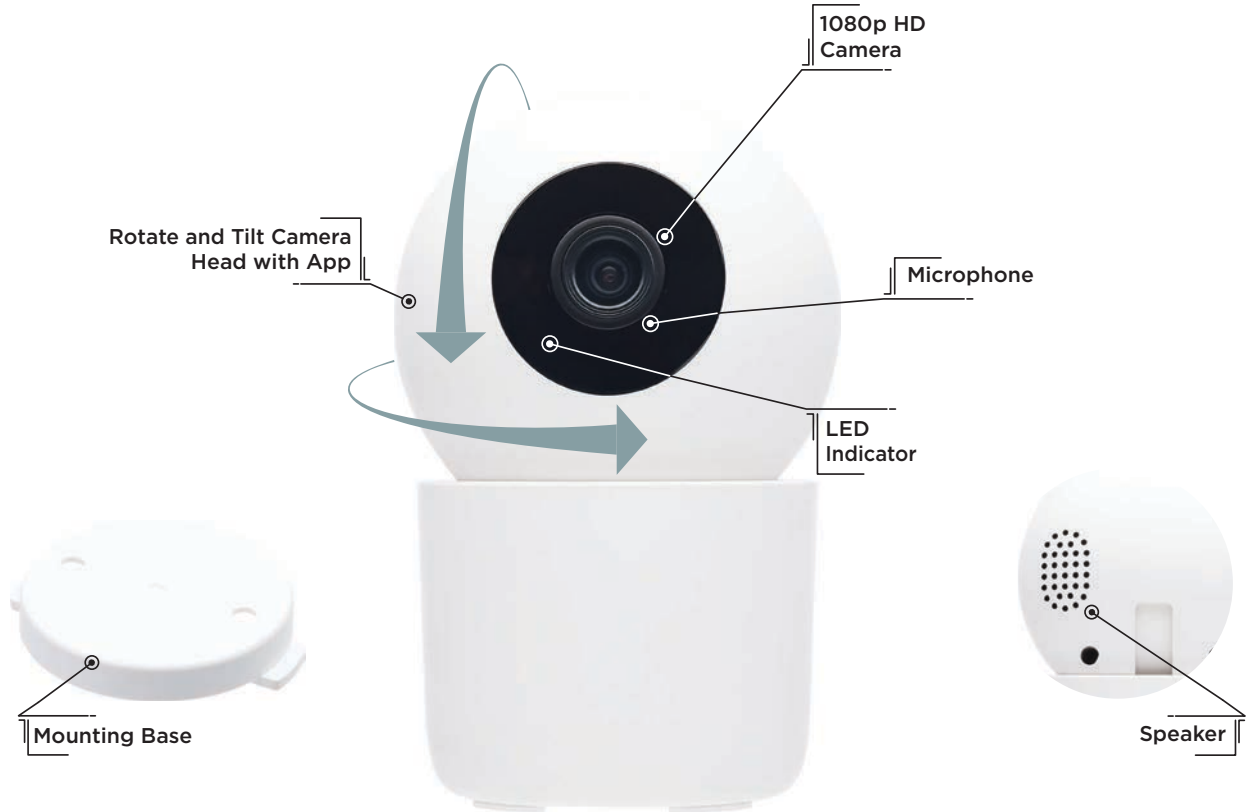

DOWNLOAD THE
STARFISH APP



CONNECT
Download the STARFISH® app

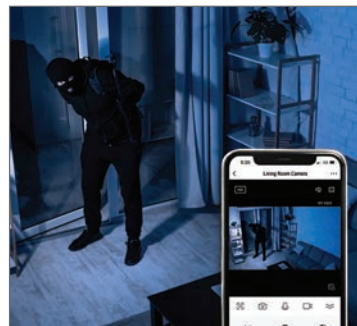

INSTALL
Pair and configure your settings



ENJOY
The convenience and customization of smart lighting

This device complies with Part 15 of the FCC Rules. Operation is subject to the following two conditions: (1) this device may not cause harmful interference, and (2) this device must accept any interference received, including interference that may cause undesired operation.

WARNING: Some products included in this specification sheet may be subject to the warning requirements of California's Proposition 65. Please refer to your product packaging for more information.

Amazon, Alexa and all related logos are trademarks of Amazon.com, Inc. and its affiliates. Siri is a registered trademark of Apple Inc. Google, Google Play and Google Home are trademarks of Google LLC.

Visit satco.com/service/warranty for complete warranty details.



ITEM SPECIFICATIONS/ORDERING INFO

Item	Finish	Width (A)	Height (B)	Extends (C)	Weight
65-945	White	2.8"	4.33"	2.76"	0.37 Lbs.

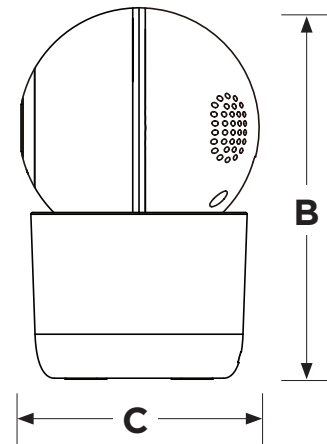
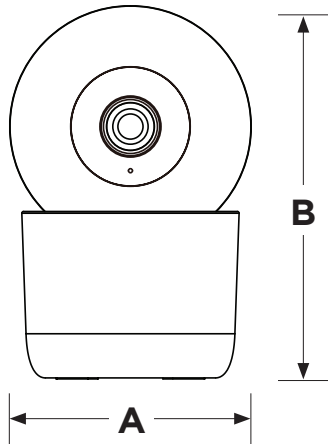

SMART INDOOR CAMERA

WHITE FINISH

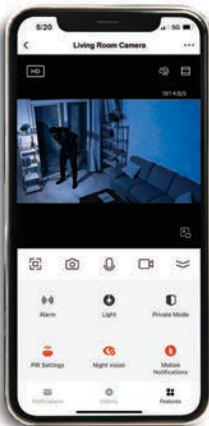

 **STARFISH**
live life enlightened



**SIMPLE PLUG & PLAY
INSTALLATION**

**REMOTE VIEWING AND
TWO-WAY TALK**

**LIVE AND EVENT HISTORY
MONITORING**

**EXPANDABLE MICRO SD
CARD STORAGE**

Easily expand home security with SATCO|NUVO's Indoor Smart Camera. Mount to the ceiling or wall to view any indoor space. View in real-time, or playback motion activated events from anywhere on your mobile device with the STARFISH® app. Discreetly listen in or actively engage in conversation with the two-way talk feature. Best of all, no subscription fees, ever.

This camera is also compatible with Google Home, Siri, SmartThings, and Alexa, including the Alexa Show.

**NO MONTHLY
SUBSCRIPTION**

STARFISH® ENABLED PRODUCT



WIFI
2.4GHz
No Hub Required



GENERAL SPECIFICATIONS

WiFi Frequency: 2.4GHz
Camera Resolution: 1080p
Field of View: 93° Diagonal
Local Storage:
 32GB SD Card Included (Expandable up to 128GB)
Finish: White

Operating Temperature:
 -20°C (-4°F) to +45°C (+113°F)
Installation: Includes double-sided mounting tape for fixed placement, Ceiling or Wall application.
Power: USB-C Cable and Plug-In adapter (included)
Warranty: 1 Year

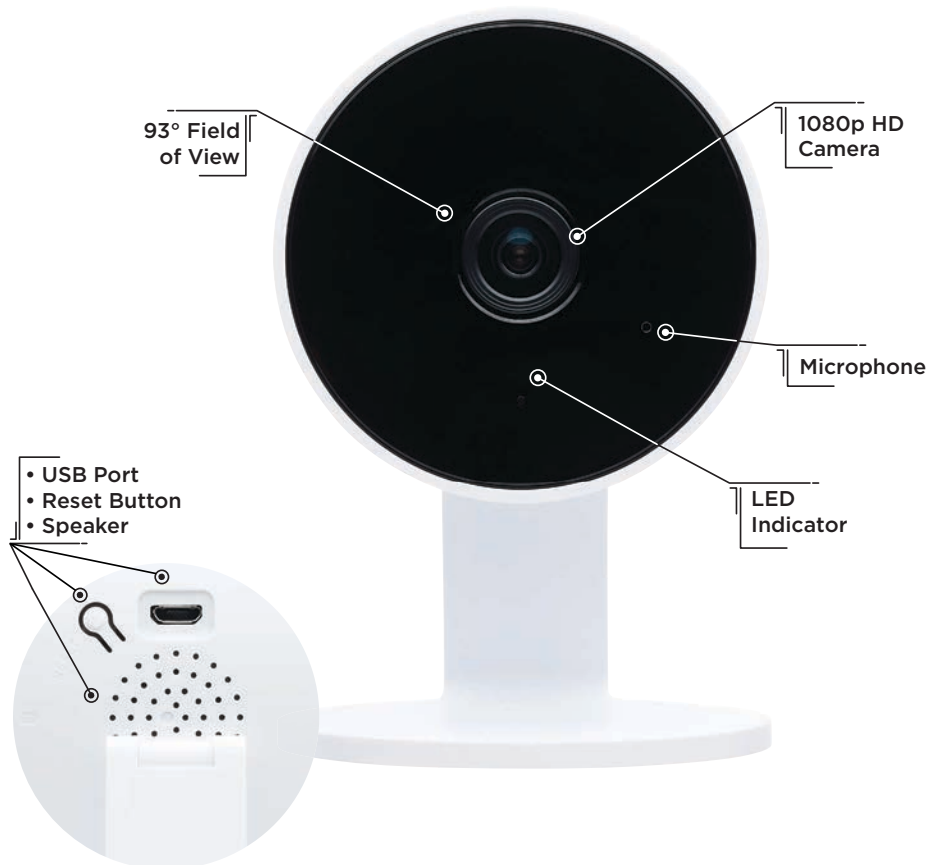

DOWNLOAD THE STARFISH APP



CONNECT
 Download the STARFISH® app

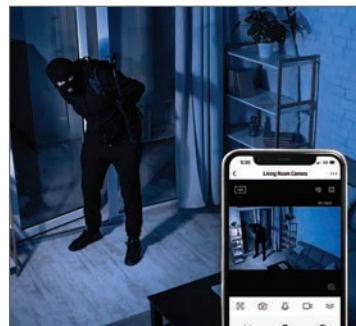

INSTALL
 Pair and configure your settings

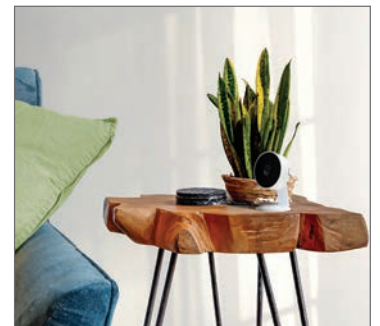

ENJOY
 The convenience and customization of smart lighting

This device complies with Part 15 of the FCC Rules. Operation is subject to the following two conditions: (1) this device may not cause harmful interference, and (2) this device must accept any interference received, including interference that may cause undesired operation.

WARNING: Some products included in this specification sheet may be subject to the warning requirements of California's Proposition 65. Please refer to your product packaging for more information.

Amazon, Alexa and all related logos are trademarks of Amazon.com, Inc. and its affiliates. Siri is a registered trademark of Apple Inc. Google, Google Play and Google Home are trademarks of Google LLC.

Visit satco.com/service/warranty for complete warranty details.



ITEM SPECIFICATIONS/ORDERING INFO

Item	Finish	Width (A)	Height (B)	Extends (C)	Weight
65-940	White	3.58"	3.58"	2.64"	0.13 Lbs.

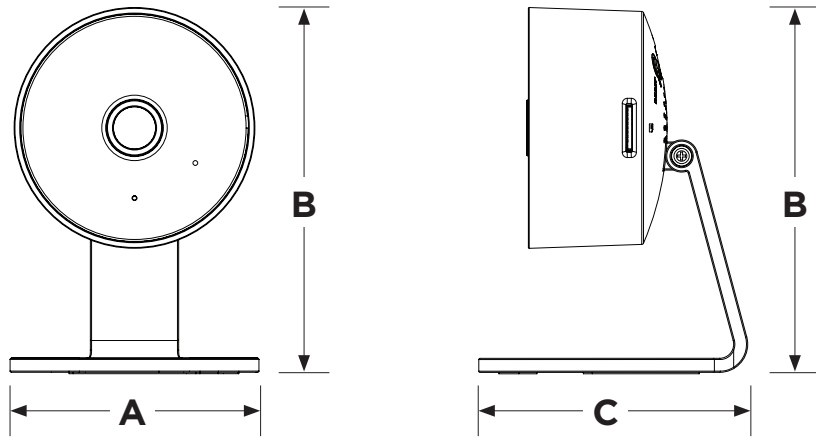

SMART PLUG

DUAL OUTLET | OUTDOOR



POWER TWO DEVICES WITH ONE DUAL OUTLET

SET-UP SCHEDULES AND TIMERS WITH THE STARFISH APP

VOICE CONTROL WITH COMPATIBLE ASSISTANTS

SUGGESTED APPLICATIONS:

- Residential
- Multifamily
- Hospitality
- Commercial

The SATCO|NUVO Outdoor Smart Plug by STARFISH is the perfect companion for managing your outdoor electronics effortlessly. Designed to withstand outdoor conditions with its wet location rating, this smart plug handles up to 15 amps and supports devices up to 0.5 horsepower. Through the STARFISH app, you can effortlessly control its power status remotely, enabling you to schedule times, turn devices on or off, and more. It's an ideal choice for controlling holiday lights, electronic decorations, as well as practical outdoor installations like ponds and fountains.



GENERAL SPECIFICATIONS

Watts: 1875W
Amps: 15.00A
Volts: 125V
Motor: 0.50 HP
WiFi: 2.4GHz
Location Rating: Wet

NEMA Type: 3R
Construction: Polypropylene
Finish: Matte Black
Power Cord: 14AWGx3C
Warranty: 3 Years

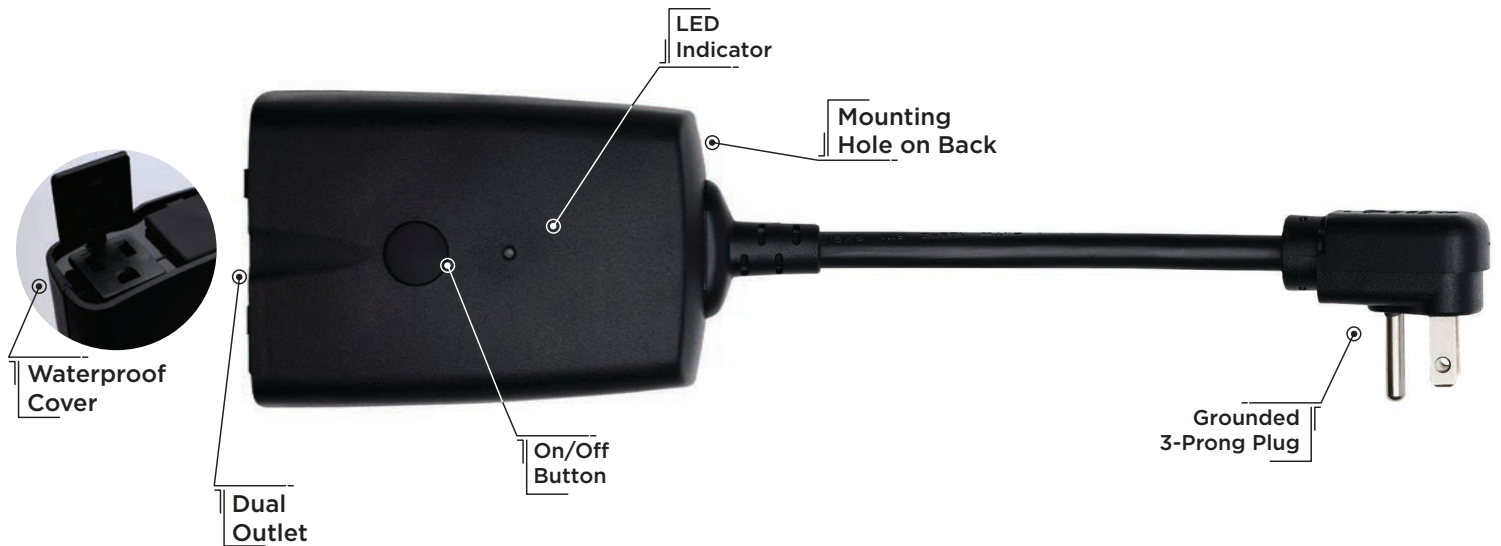

DOWNLOAD THE
STARFISH APP



CONNECT
Download the STARFISH® app



INSTALL
Pair and configure your settings



ENJOY
The convenience and customization of smart lighting

This device complies with Part 15 of the FCC Rules. Operation is subject to the following two conditions: (1) this device may not cause harmful interference, and (2) this device must accept any interference received, including interference that may cause undesired operation.

WARNING: Some products included in this specification sheet may be subject to the warning requirements of California's Proposition 65. Please refer to your product packaging for more information.

Amazon, Alexa and all related logos are trademarks of Amazon.com, Inc. and its affiliates. Siri is a registered trademark of Apple Inc. Google, Google Play and Google Home are trademarks of Google LLC.

Visit satco.com/service/warranty for complete warranty details.



ITEM SPECIFICATIONS/ORDERING INFO

Item	Finish	Length (A)	Height (B)	Width (C)	Weight
S11281	Matte Black	2.99"	4.17"	2.76"	0.50 Lbs.

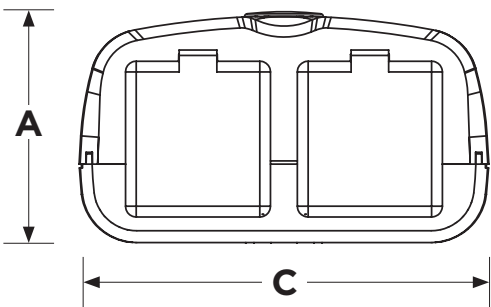
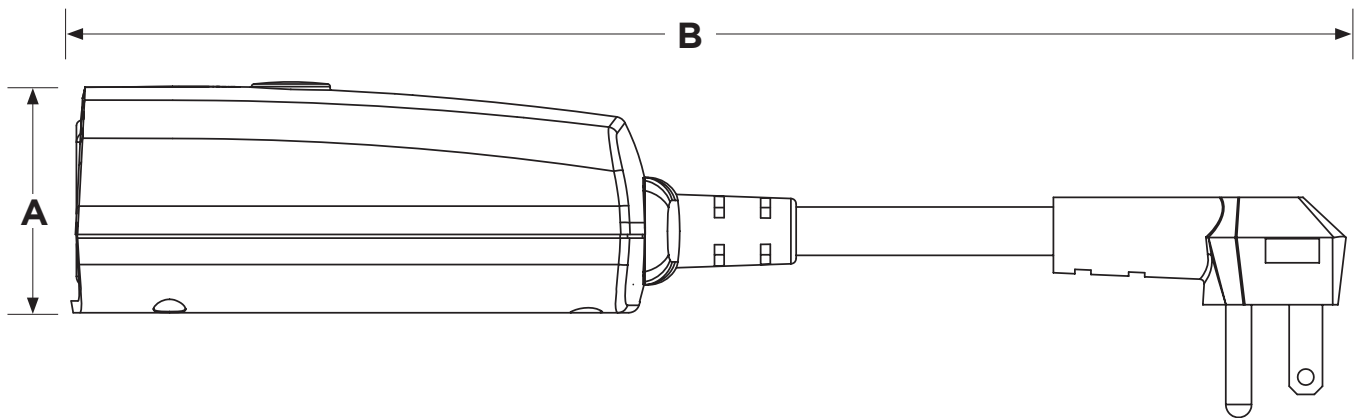

AUSTEN COLLECTION

OUTDOOR LED SMART LANTERN



STARFISH
Controlled with App



Millions of Colors

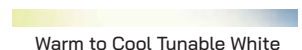

Warm to Cool Tunable White



SATCO|NUVO's Austen Collection of Outdoor LED Smart Lanterns with STARFISH® technology are the sophisticated choice for smart lighting and ambiance control. Download the STARFISH® app to customize any tunable white color temperatures from 2700K warm white light to 5000K natural light, or choose from millions of colors on the RGB spectrum, all from your mobile device. Offered as wall and hanging lanterns, these outdoor fixtures offer durable black housing with clear water glass for a timeless look with modern amenities.

These elegant fixtures are also compatible with Siri, Alexa, Google Home, and SmartThings so they can be easily incorporated into your smart home.

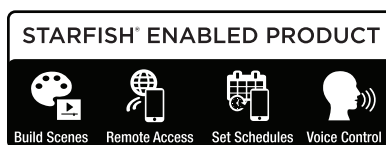

**WALL & HANGING LANTERN
OPTIONS OFFERED**

**STARFISH® SMART ENABLED
PRODUCT**

**RGB, COLOR-CHANGING &
TUNABLE WHITE**

**PRE-SET AND CUSTOM
COLOR-CHANGING EFFECTS**

SUGGESTED APPLICATIONS

Residential
Multifamily
Hospitality

GENERAL SPECIFICATIONS

Input Voltage, Frequency: 120V, 60Hz
Power Factor, THD%: >0.5, <20%
Tunable White CCT: 2700K-5000K
RGB: Millions of colors
Dimmable: Only with STARFISH® app
CRI: 80
Efficacy: up to 85 LPW

Construction: Die-Cast Aluminum
Finish: Matte Black
Glass Type: Clear Water Glass
Ambient Operating Temperature: -40°C (-40°F) to +40°C (+104°F)
Functional Life: 35,000 Hours
Warranty: 1 Year



ITEM SPECIFICATIONS/ORDERING INFO

Item	Description	Lumens	Wattage	Location Rating	Chain Length	Wire Length	Length/Width (A)	Height (B)	Extension (C)	Weight
62-5996	Hanging	850	10W	Damp	48"	144"	7.75"	17.75"	--	6.03 Lbs.
62-5997	Wall	850	10W	Wet	--	--	6.00"	13.25"	7.75"	3.57 Lbs.

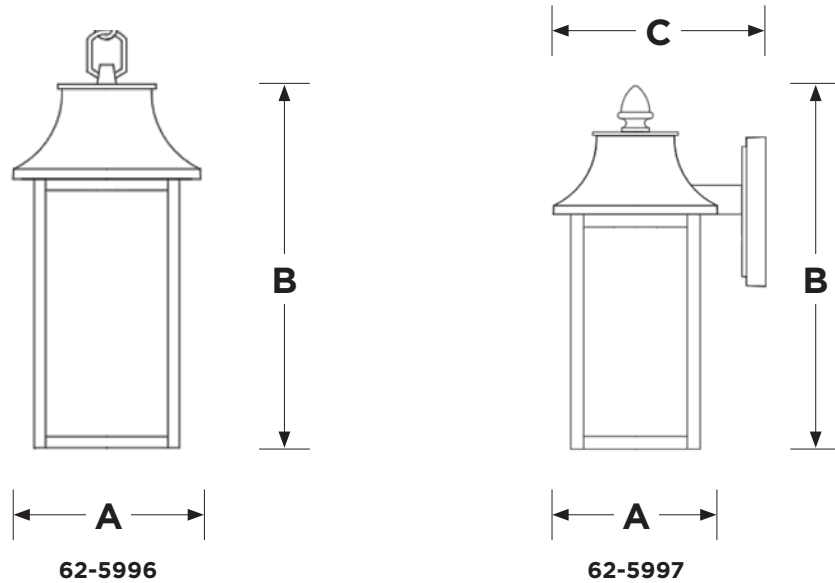

DOWNLOAD THE STARFISH APP



CONNECT
Download the STARFISH™ app



INSTALL
Pair and configure your settings



ENJOY
The convenience and customization of smart lighting

This device complies with Part 15 of the FCC Rules. Operation is subject to the following two conditions: (1) this device may not cause harmful interference, and (2) this device must accept any interference received, including interference that may cause undesired operation.

WARNING: Some products included in this specification sheet may be subject to the warning requirements of California's Proposition 65. Please refer to your product packaging for more information.

Amazon, Alexa and all related logos are trademarks of Amazon.com, Inc. and its affiliates. Siri is a registered trademark of Apple Inc. Google, Google Play and Google Home are trademarks of Google LLC.

Visit satco.com/service/warranty for complete warranty details.

EAST RIVER COLLECTION

OUTDOOR LED SMART LANTERN



STARFISH
Controlled with App



Millions of Colors

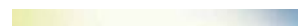

Warm to Cool Tunable White

SATCO|NUVO's East River Collection of Outdoor LED Smart Lanterns with STARFISH® technology are the sophisticated choice for smart lighting and ambiance control. Download the STARFISH® app to customize any tunable white color temperatures from 2700K warm white light to 5000K natural light, or choose from millions of colors on the RGB spectrum, all from your mobile device. Offered as hanging and wall lanterns, these outdoor fixtures offer durable black housing with clear water glass for a timeless look with modern amenities.

These elegant fixtures are also compatible with Siri, Alexa, Google Home, and SmartThings so they can be easily incorporated into your smart home.



STARFISH® ENABLED PRODUCT

Build Scenes Remote Access Set Schedules Voice Control

WIFI
2.4GHz
No Hub Required



HANGING AND WALL
LANTERN OPTIONS OFFERED

STARFISH® SMART ENABLED
PRODUCT

RGB, COLOR-CHANGING &
TUNABLE WHITE

PRE-SET AND CUSTOM
COLOR-CHANGING EFFECTS

SUGGESTED APPLICATIONS

Residential
Multifamily
Hospitality

GENERAL SPECIFICATIONS

Input Voltage, Frequency: 120V, 60Hz
Power Factor, THD%: >0.5, <20%
Tunable White CCT: 2700K-5000K
RGB: Millions of colors
Dimmable: Only with STARFISH® app
CRI: 80
Efficacy: up to 85 LPW

Construction: Die-Cast Aluminum
Finish: Matte Black
Glass Type: Clear Water Glass
Ambient Operating Temperature: -40°C (-40°F) to +40°C (+104°F)
Functional Life: 35,000 Hours
Warranty: 1 Year



ITEM SPECIFICATIONS/ORDERING INFO

Item	Description	Lumens	Wattage	Location Rating	Chain Length	Wire Length	Length/Width (A)	Height (B)	Extension (C)	Weight
62-5944	Hanging	850	10W	Damp	48"	144"	8.5"	14.5"	--	4.26 Lbs.
62-5945	Wall	850	10W	Wet	--	--	6.25"	12.00"	7.38"	2.71 Lbs.

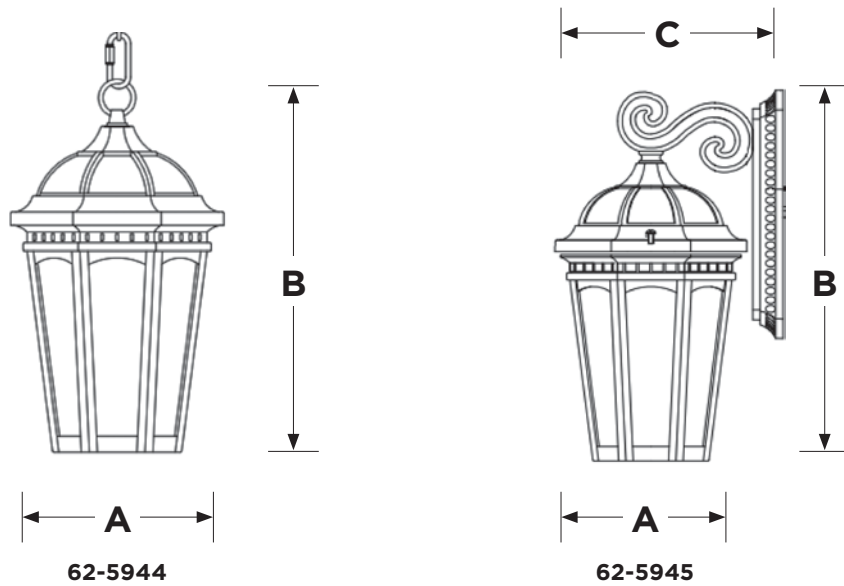

DOWNLOAD THE STARFISH APP



CONNECT
Download the STARFISH™ app



INSTALL
Pair and configure your settings



ENJOY
The convenience and customization of smart lighting

This device complies with Part 15 of the FCC Rules. Operation is subject to the following two conditions: (1) this device may not cause harmful interference, and (2) this device must accept any interference received, including interference that may cause undesired operation.

WARNING: Some products included in this specification sheet may be subject to the warning requirements of California's Proposition 65. Please refer to your product packaging for more information.

Amazon, Alexa and all related logos are trademarks of Amazon.com, Inc. and its affiliates. Siri is a registered trademark of Apple Inc. Google, Google Play and Google Home are trademarks of Google LLC.

Visit satco.com/service/warranty for complete warranty details.



**STARFISH®
SMART ENABLED PRODUCT**

**ADVANCED PAIRING
TECHNOLOGY**

**RGB, COLOR-CHANGING &
TUNABLE WHITE**

**PRE-SET AND CUSTOM
COLOR-CHANGING EFFECTS**

SUGGESTED APPLICATIONS
Residential, Multi-Family,
Offices, Commercial, Retail,
Hospitality and Industrial

SMART LED LANDSCAPE FLOOD LIGHTS

BRONZE FINISH



STARFISH®
Controlled with App



Millions of Colors



Warm to Cool Tunable White

SATCO|NUVO's LED Landscape Flood Lights with STARFISH® technology is the sophisticated choice for smart outdoor lighting. Download the STARFISH app to customize any tunable white color temperatures from 2700K warm white light to 5000K natural light or choose from millions of colors on the RGB spectrum, all from your mobile device. Build scenes and set schedules to customize ambiance and create a unique lighting experience.

These fixtures are also compatible with Siri, Alexa, Google Home, and SmartThings so they can be easily incorporated into your smart home.

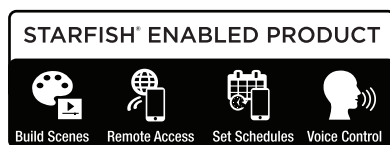

GENERAL SPECIFICATIONS

Input Voltage: 120V
Frequency: 60Hz
Power Factor: >0.5
THD%: <20%
Dimmable: Only with STARFISH® App
Efficacy: up to 103 LPW
CCT Tunable: 2700K-5000K
RGB: Millions of Colors
CRI: 90+

Beam Angle: 60°
Location Rating: Wet
IP Rating: IP65
Ambient Operating Temperature: -20°C (-4°F) to +40°C (+104°F)
Construction: Die-Cast Aluminum
Lens Construction: Acrylic
Base: 1/2" Threaded
Mounting Options: Pole/Post/Plate (Mounting Plate Included)
Functional Life: 50,000 Hours
Warranty: 5 Years



ITEM SPECIFICATIONS / ORDER INFO

Item	Style	Lumens	Wattage	Replacement Wattage	Input Current
62-5901	PAR16	480	6W	45W	0.05A
62-5902	PAR20	800	9W	65W	0.08A
62-5903	PAR30	1240	12W	75W	0.08A

PRODUCT DIMENSIONS

Item	Length (A)	Diameter (B)	Height (C)	Weight
62-5901	5.50"	2.45"	3.25"	0.62 Lbs.
62-5902	6.25"	2.63"	4.00"	0.71 Lbs.
62-5903	12.20"	5.51"	4.92"	1.75 Lbs.

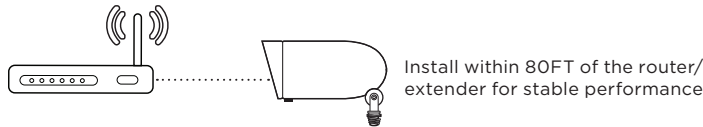
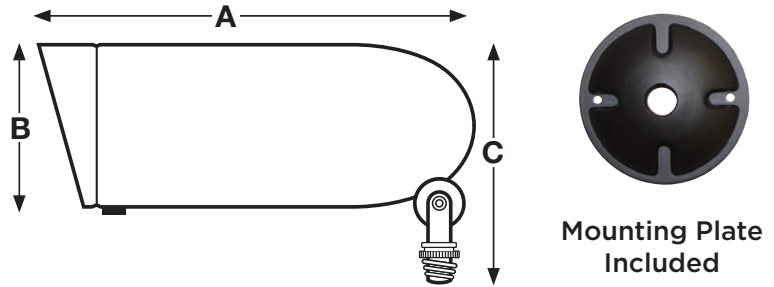

DOWNLOAD THE STARFISH APP



CONNECT
Download the STARFISH® app



INSTALL
Pair the smart products and configure settings



ENJOY
The convenience of unlimited features

This device complies with part 15 of the FCC Rules. Operation is subject to the following two conditions: (1) this device may not cause harmful interference, and (2) this device must accept any interference received, including interference that may cause undesired operation.

Amazon, Alexa and all related logos are trademarks of Amazon.com, Inc. and its affiliates. Siri is a registered trademark of Apple Inc. Google, Google Play and Google Home are trademarks of Google LLC.

Warning: This product can expose you to chemicals including lead, which is known to the State of California to cause cancer and birth defects or other reproductive harm. For more information go to www.P65Warnings.ca.gov.

To learn more about SATCO|NUVO, visit www.satco.com or contact 1-800-437-2826



Like us on Facebook



Connect with us on LinkedIn



Follow us on Instagram

National Toll-Free: 1.800.43.SATCO (1.800.437.2826)

Corporate Offices &

Distribution Center: **NEW YORK** 110 Heartland Blvd., Brentwood, NY 11717 | 800.437.2826 | 631.243.2022 | Fax 631.243.2027

Distribution Centers: **FLORIDA** 1694 NW 215th St. Miami Gardens, FL 33056 | Tel. 305.624.2044 FAX 305.623.0286

CALIFORNIA 31288 San Benito St. Hayward, CA 94544 | Tel. 510.487.4822 FAX 510.487.8955

WASHINGTON 4710 116th St. S.W., Mukilteo, WA 98275 | Tel. 425.789.3300 FAX 425.789.3310

TEXAS 2000 Valwood Parkway, Farmers Branch, TX 75234 | Tel. 972.247.2437 FAX 972.247.5408

PUERTO RICO Campeche St. 23, Julio N. Matos Industrial Park, Carolina, PR 00984 | Tel. 787.757.3510 FAX 787.757.3540

Product specifications and availability are subject to change without notice.
Please visit us online at www.satco.com for our full product line and ordering details, or consult factory for additional information